

Measuring and diagnosis solutions for inspecting MEP/HVAC components

Deliverable report: 1.7



Deliverable report: 1.7: Final Version, issue date on 9 November 2018

Intuitive Self-Inspection Techniques using Augmented Reality for construction, refurbishment and maintenance of energy-efficient buildings made of prefabricated components.

This research project has received funding from the European Union's H2020 Framework Programme for research and innovation under Grant Agreement no 636063.

Measuring and diagnosis solutions for inspecting MEP/HVAC components

Deliverable report: 1.7

Issue Date	31 Augustus, 2018, revised issue date 09 November 2018	
Produced by	WP1	(IAA WP leader)
Main author	Gaby Abdalla	(DWA)
Co-authors	Arjan Broers Manuel Andrés Chicote	(ISSO) (CARTIF)
Version:	Final	
Reviewed by	Carlos Bárcena Ruud Geerligs	(Dragados) (DMO)
Approved by	Rizal Sebastian – Technical Coordinator Oana Schippers – Trifan – Operational Coordinator	(DMO) (DMO)
Dissemination	Public	

Colophon

Copyright © 2018 by INSITER consortium

Use of any knowledge, information or data contained in this document shall be at the user's sole risk. Neither the INSITER Consortium nor any of its members, their officers, employees or agents accept shall be liable or responsible, in negligence or otherwise, for any loss, damage or expense whatever sustained by any person as a result of the use, in any manner or form, of any knowledge, information or data contained in this document, or due to any inaccuracy, omission or error therein contained. If you notice information in this publication that you believe should be corrected or updated, please contact us. We shall try to remedy the problem.

The authors intended not to use any copyrighted material for the publication or, if not possible, to indicate the copyright of the respective object. The copyright for any material created by the authors is reserved. Any duplication or use of objects such as diagrams, sounds or texts in other electronic or printed publications is not permitted without the author's agreement.

This research project has received funding from the European Union's H2020 Framework Programme for research and innovation under Grant agreement no 636063.

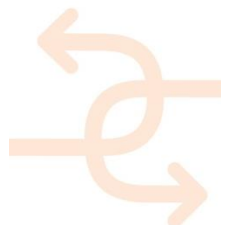

Fulfilment of the Description of Action in D1.7

Accessibility of this deliverable

This deliverable is presented in 1 part: Report / documentation (this document). For INSITER consortium and European Commission representatives, the deliverable is available both in the EC Participant Portal (INSITER project) as well as in the SharePoint project website.

After approval by the European Commission, the public version of this deliverable will be published on the INSITER public website, and disseminated through the common dissemination channels.

Fulfilment of WP, Task and Deliverable scope and objectives

Summarised objectives as stated in DoA	Results presented in this deliverable
<p>WP 1 scope and objectives:</p> <ul style="list-style-type: none"> • Key Measurement aspects and parameters addressing quality and energy performance • Techniques for self-inspection and self-instruction in different types of projects (new construction, refurbishment, commissioning, and maintenance). 	<p>Addressed:</p> <ul style="list-style-type: none"> • For each critical HVAC component, subsystem and system the relevant KPIs have been elaborated, based on early findings from D1.1 and D1.6 (see 4.2, 5.2, 6.2 and 7.2). • Development of a new diagnosis approach based on use of simulation techniques for supporting performance measurements and self-inspection processes (see Chapter 3). • Development of diagnosis solution for self-inspecting HVAC/MEP subsystems (see 4.4, 5.4, 6.4 and 7.4). • Elaboration of the new approaches in the INSITER methodology (see Chapter3).



Summarised objectives as stated in DoA	Results presented in this deliverable
<p>Task 1.3 scope and objectives:</p> <ul style="list-style-type: none"> Investigating MEP/HVAC critical components (e.g. valves, pumps), sub-systems (e.g. heat pumps), and systems (e.g. heating/cooling systems), by reflecting on their specific properties and KPIs for energy-performance. Identification of difficulties in assessment and analysis of MEP/HVAC systems during construction and refurbishment. Real measurement of the systems performance (e.g. pump operation, fans, etc.) depends on the variable installation solutions (e.g. pipe length, calibration). There is a need for methodologies for the non-invasive and cost-effective assessment to detect faults and measure/estimate the performance. Adaptation and further development of existing inspection techniques and instruments (e.g. flow measuring), with their best practices and shortcomings, as input to develop self-inspection techniques. Integrating the calculation and simulation methods (such as TRNSYS) and monitoring techniques (such as MONAVISA) in BIM; implementing the techniques and information based on BIM. The uncertainty of each key performance parameter measured must be estimated and the weight of each parameter on the global building performance calculated. Methods based on propagation of uncertainty sources (connected with sensors, model assumptions, discretization errors, etc.) using statistical algorithms as SRC (Standardized Regression Coefficients) can be implemented. This will allow evaluating the statistical confidence level in the achieved results and thus supporting all the successive decision tacking procedures (e.g. maintenance, control). Elaborating the process methods for self-inspection, embedded in the conventional and integrated collaborative processes in construction. Extracting self-instruction information as guidelines for the construction workers. Embedding self-inspection in the quality assurance systems and standardisation. 	<p>Addressed in D1.6:</p> <ul style="list-style-type: none"> The first two objectives are already addressed in D1.6 resulting in: definitions of HVAC/MEP (different levels), real measurement of the systems performance, identification of assessment difficulties and methodologies for non-invasive and cost-effective assessments. <p>Addressed in D1.7:</p> <ul style="list-style-type: none"> Integration of simulation techniques for self-inspection purposes; Developing methods for defining thresholds for performance deviations; Elaborating of the diagnosis approach in the new self-inspection process methodology; Elaborating of the new self-inspection process methodology in the main building process; and Embedding self-inspection methods in the quality assurance systems and standardisation. <p>Not addressed:</p> <ul style="list-style-type: none"> Integration of monitoring technique for self-inspection purposes. Monitoring technique are part of the quality control in the use stage of the building. In the construction stage, which the INSITER project focuses on, no actual sensors data are available and therefore no monitoring is possible.
<p>Deliverable D1.7 scope and objectives:</p> <ul style="list-style-type: none"> Practical measurement protocols supported by hardware and software tools for self-inspection of MEP/HVAC components. It presents practical techniques (protocols) supported by hardware and software for self-inspection in all phases of a building project. 	<p>Specific results fulfilling the deliverable objectives:</p> <ul style="list-style-type: none"> A new approach for self-inspection based on calculation and simulation techniques (Chapter 3, Chapter 4, Section 5.4, Section 6.4 and Section 7.4). A new approach to determine thresholds and evaluation of performance deviation based on calculation and simulation possibilities (Chapter 3).

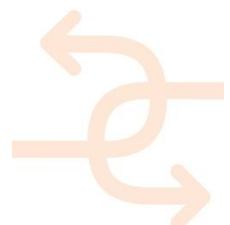

Publishable executive summary

Research on measuring and diagnosis solutions for inspecting HVAC/MEP components concentrates on developing practical measurements protocols supported by hardware and software tools for self-inspection of HVAC/MEP components. Together with already presented protocols, presented by D1.6, the new protocols cover all phases of a building project (within the scope of the INSITER project). The main objectives of this deliverable are:

1. To integrate the calculation and simulation methods (such as TRNSYS and Vabi Elements) in the BIM approach of the INSITER methodology;
2. To define methods to determine the uncertainty of each key performance parameter measured and its impact on the global building performance;
3. To define methods to determine thresholds for deciding on performance deviations of components and systems;
4. To integrate the new approach in the quality control process.

From the research that is done in D1.1 (Best practices and shortcomings), D1.4 and D1.6 (Calculation and analytical methods for building & HVAC/MEP components) this document builds on the measuring and diagnosis solutions for inspecting MEP/HVAC components. D1.7 and its counterpart D1.5 for the building envelope cover the whole self-inspection techniques and quantifying methods for building and HVAC/MEP components. Findings from T1.3 have impact on the self-inspection process and thus also on the 8 steps methodology. Findings and related recommendations have been integrated in the self-inspection process.

Mass-production HVAC/MEP components

The most components of HVAC/MEP systems are mass-produced products. Generally speaking these mass-production components undergo very dedicated quality control processes. We talk in this case about prefabricated elements. Besides, complicated components and subsystems (such as heat pumps) are installed by dedicated teams including manufacturer specialists. They deliver well-functioning components including all requested inspection reports. The most crucial quality issues related to mass-production components are related to using proper settings and right mutual interaction between the connected components. These issues are, currently, a part of the initial commissioning (Cx) that has to be performed by the commissioning authorities; not by the workers themselves.

Current commissioning

Current commissioning services are based on inspecting the work done by workers during construction activities. In the most projects, commissioning covers the stage between the end of the construction stage (including installing and mounting of HVAC/MEP systems) and the handover stage. According to services developed by DWA, commissioning is based on four pillars of inspection: quantity, quality, functionality and performance (see Figure 1).

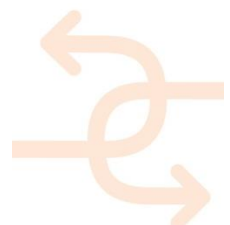

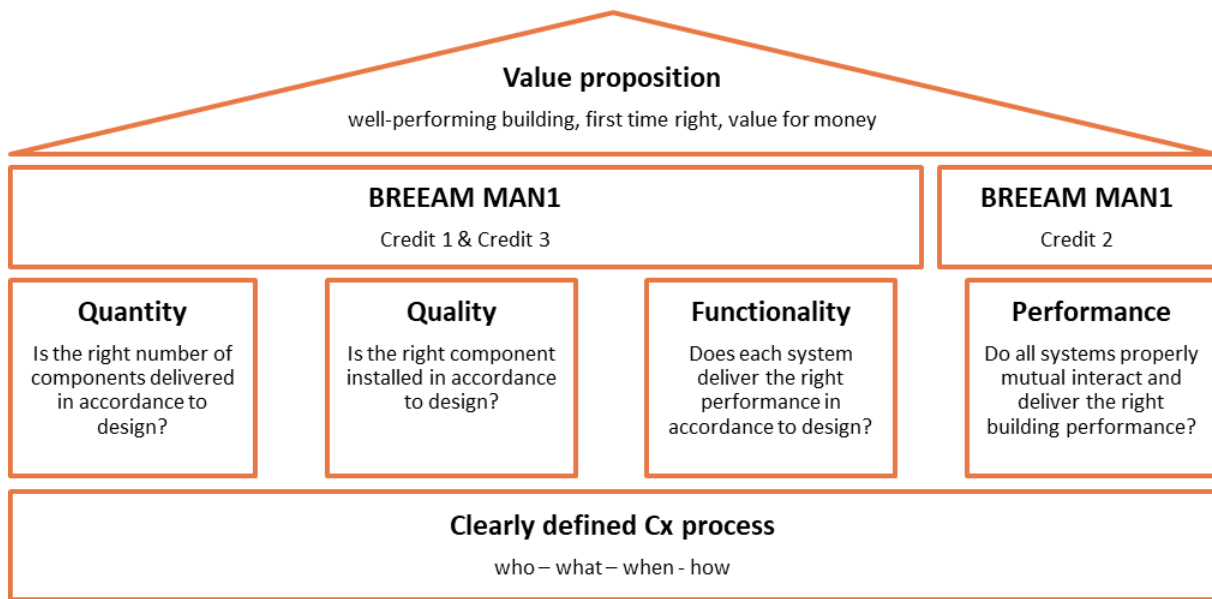

Figure 1: the commissioning services according to the DWA business

The INSITER project aims to increase building quality and energy performance through supporting workers faultlessly performing their work and properly self-inspecting the quality on solid basis. The new INSITER methodology strengthens the initial commissioning approach by re-structuring the inspection processes by the workers and supporting them by more self-instruction and self-inspection methods and tools. Besides, talking about responsibility issues, it is transferring more responsibilities tot workers during to the construction phase.

T1.3 builds up on already existing inspection and initial commissioning practices. It provides solutions to overcome difficulties in the current (self-) inspection and commissioning processes. Construction workers get better possibilities to improve their work and making the right decisions based on experience, software and hardware.

Difficulties in the current self-inspection process

Actual performance of the building and related HVAC/MEP systems (considering energy efficiency or building quality KPI's) is a function of several factors including quality of building envelope/elements, performance of (all) HVAC/MEP systems (and all related subsystems & components), weather conditions and use & user influence. Therefore, functional tests in many cases depend on the completion of the system.

For example, the functional test of the control system must be largely completed and tested before being able to perform functional tests on the heat pump. Another example is the impact of seasonal/weather conditions and building occupancy on the actual performance of the HVAC/MEP systems. Therefore it takes, in the most cases, one year after delivery and occupancy to decide if the whole building, including all HVAC/MEP systems, is performing as designed.

There is thus a need to develop methods supporting inspection and decision making processes during the construction and self-inspection processes by the workers themselves.

In D1.7 as a part of T1.3, a simulation based approach has been developed to cover this performance gap.

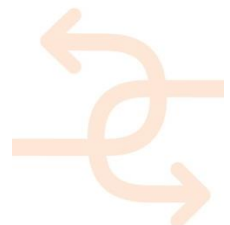

A new diagnosis approach

D1.6, as a deliverable of T1.3, has already reported on self-inspection methodology based on insights from past experience. It contains lists of common errors and critical components. Workers can, herewith, effectively and efficiently self-inspecting components and subsystems. D1.6 provided also measurement protocols and quantitative methods supporting self-inspection by workers. For performance measurements and evaluation of possible performance deviations a new diagnosis approach is developed based on simulation techniques.

The new approach is based on simulating (total) building performance using deviated performance of critical components/systems as input. By doing that, actual performance under measured deviations will be mimicked by simulation techniques. Figure 2 illustrates the use of simulation techniques for the new diagnosis approach.

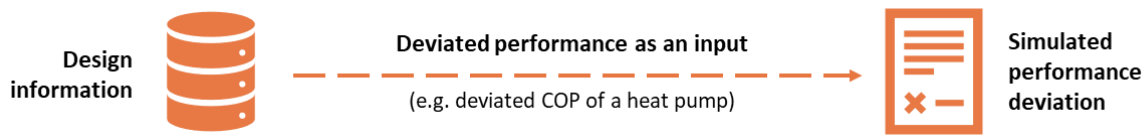

Figure 2: simplified visualisation of the new simulation-based diagnosis approach

The simulation step will be repeated using a range of performance deviations. This will result in a relationship between measured performance and its impact on KPI in target. This relationship can be visualised in a graph; a diagnosis diagraph. Workers use such graphs during self-inspection processes to decide on impact of possible deviation on building performance and if the measured deviation will be accepted or rejected.

Updating the self-inspection process

Simulation-based self-inspection is a valuable approach for the total quality control process introduced by the INSITER project. Together with Experience-based self-inspection and Monitoring-based inspection, performance gap between design and realisation can be closed (see Figure 3). However, the latter two are outside of the scope of the INSITER project.

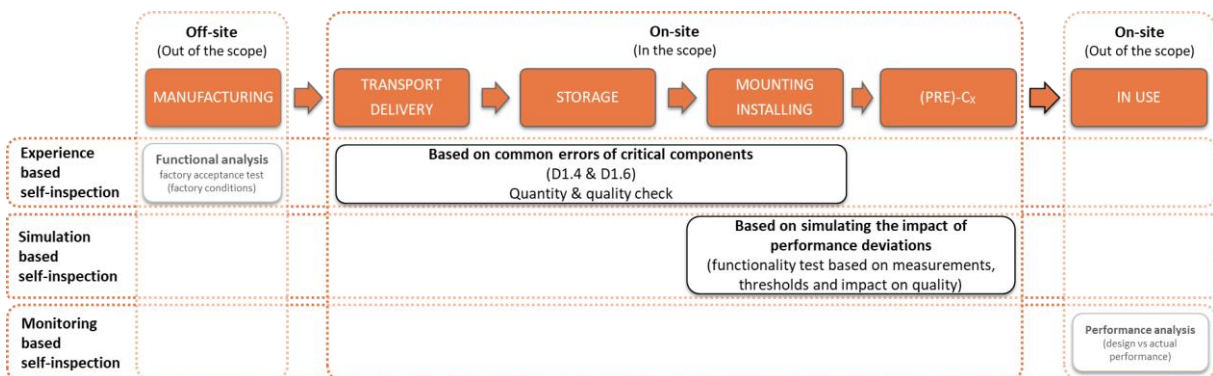
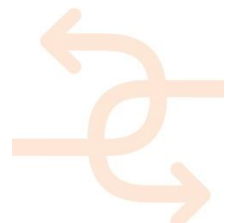

Figure 3: Different self-inspection methodologies in the different stages of the project



The self-inspection process is integrated in INSITER's 8 step methodology. This methodology describes a detailed procedure where newly developed methods, tools and techniques contribute to INSITER's goal to close the gap between design and realization. Self-inspection on MEP/HVAC components takes place in different steps of the methodology and in different phases throughout the building process. Figure 4 illustrates an updated version of the 8-step methodology and related self-inspections.

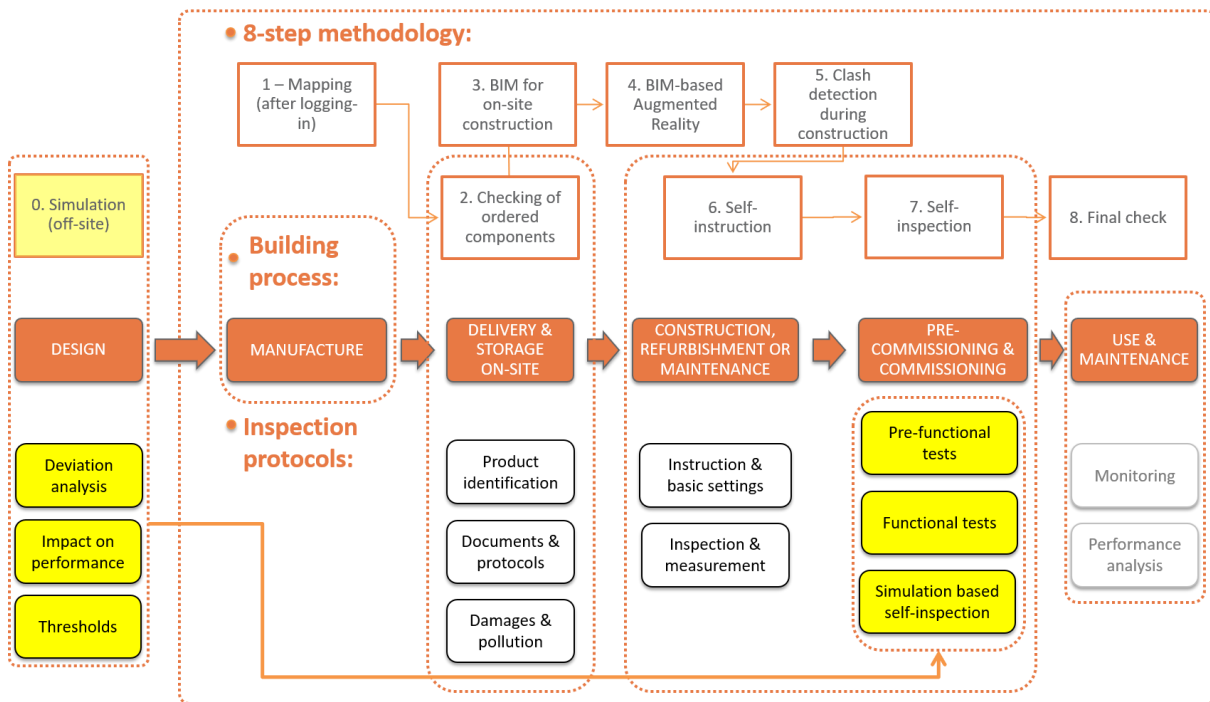
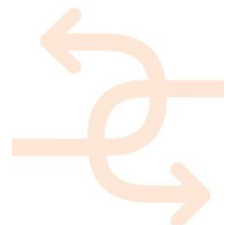

Figure 4: an update 8-step methodology for MEP/HVAC components during the different building phases

All inspection revolves around the same concept: to eliminate errors that have major influence on a definite list of KPIs. Because of the complex multitude of actions, INSITER's methodology will follow a structural approach. This method follows a bottom-up concept of eliminating errors. The levels of inspection are defined as 'components', 'subsystems', and 'systems' van bottom to top following::

01. Prevent that damaged or polluted components are installed;
02. Prevent that wrong components are installed;
03. Ensure that components are installed incorrectly;
04. Ensure that components are provided with the wrong settings; and
05. Ensure that components properly interact with each other.

The new approach is applied, where possible and valuable, in Chapters 4, 5, 6 and 7. Just like D1.6, D1.7 considers four leading MEP systems in the building, together covering for over 90% of all MEP systems with a relation to indoor environment and energy usage. These systems are: Heating & cooling (with heat pump); Mechanical ventilation (with heat recovery); Solar hot water and LED Lighting.



Applicability

The diagnosis solutions have been applied for the four HVAC/MEP systems in Section 4, 5, 6 and 7. The new simulation-based diagnosis approach is only applied to the COP of the heat pump because of the complexity of performance measuring of the heat pump. The INSITER project concentrates only on solutions that support workers performing self-inspection processes without burdening their process. Issues related to the applicability of the approach and related limitations have been extensively discussed.

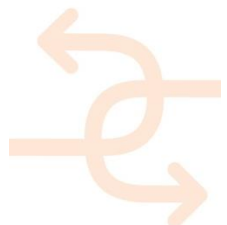

List of abbreviations and symbols

- AEC: Architecture, Engineering, and Construction
- AHU: Air Handling Unit
- AR: Augmented Reality
- ATES: Aquifer Thermal Energy Storage
- BIM: Building Information Modelling
- BVU: Bidirectional Ventilation Unit
- CAV: Constant Air Volume (in contrast to VAV)
- Cx: Commissioning
- DCV: Demand-controlled ventilation
- DHW: Domestic Hot Water
- DoA: Description of the Action
- DoW: Description of the Work
- DX: Direct eXpansion
- EE: Energy Efficiency
- ERV: Energy Recovery Ventilator (or ventilation)
- HRV: Heat Recovery Ventilator (or ventilation)
- HVAC: Heating, Ventilation, Air Conditioning
- IAQ: Indoor Air Quality
- KPI: Key Performance Indicator
- MEP: Mechanical, Electrical & Plumbing
- MTT: Method, Tools, and Techniques
- MVHR: Mechanical Ventilation Heat Recovery
- NRVU: Non-Residential Ventilation Unit
- PFT: Pre-Functional Testing
- PMV: Predicted Mean Vote
- PPD: Predicted Percentage Dissatisfied
- RVU: Residential Ventilation Unit
- TAB: Testing, Adjusting and Balancing
- UVU: Unidirectional Ventilation Unit
- VAV: Variable Air Volume (in contrast to CAV)
- VU: Ventilation Unit

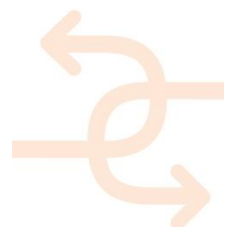

Symbols

Symbol	Quantity	Unit
A	Area	m ²
C	Effective heat capacity of a conditioned space	J/K
c	Specific heat capacity	J/(kg·K)
E	Energy	MJ
H	Heat transfer coefficient	W/K
h	Surface coefficient of heat transfer	W/(m ² ·K)
Q	Quantity of heat	MJ
R	Thermal resistance	(m ² ·K)/W
T	Thermodynamic temperature	K
t	Time, period	Ms
V	Volume of air in a conditioned zone	m ³
q	Airflow rate	m ³ /s
Φ	Heat flow rate, thermal power	W
Z	Heat transfer parameter for solar walls	W/(m ² ·K)
η	Efficiency, utilisation factor	-
θ	Celsius temperature	°C
ρ	Density	kg/m ³
τ	Time constant	h

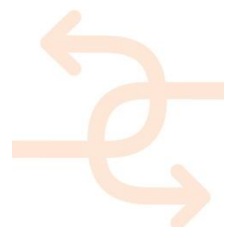

Definitions

Commissioning (Cx)

Commissioning MEP/HVAC systems is the process of verifying that these systems achieve the project requirements of new buildings as intended by the building owner and as designed by the building architects and engineers.

Commissioning activities normally consist of operating the MEP systems and making adjustments necessary for satisfactory operation of the system or part thereof. Also included are functional checks of components and subsystems, to prove that the component or subsystem functions correctly. Commissioning can be applied throughout the lifetime of the building.

Conditioned space

A conditioned space is that part of a building that is heated or cooled, or both, for the comfort of occupants.

Construction worker

The term 'construction worker' is used generically for all workers on-site, regardless their trade. Amongst construction workers are carpenters and masons, but also electricians, plumbers, and HVAC mechanics.

Exhaust air

Air flow discharged to the atmosphere.

Heat (energy) recovery ventilation system

A heat or energy recovery ventilation system is a device or combination of devices applied to provide the outdoor air for ventilation in which energy is transferred between the intake and exhaust airstreams. There are different types of heat (energy) recovery systems with different specifications and different performances. Some heat recovery systems can also recover moisture.

- Air heat exchanger is the heat exchange element used in air handling units
- Heat recovery unit is a device with build in (air) heat exchanger.
- Heat recovery ventilation (HRV) or mechanical ventilation heat recovery (MVHR) is the ventilation system with heat recovery.

HVAC component

Components that are part of the HVAC system such as filters, valves, tabs, sensors, pipes..

HVAC subsystem

The parts of the Heating (such as the heat pump and distribution circuit), Ventilation (such as the central air handling unit) and Air-Conditioning subsystem.

HVAC system

The whole of the Heating subsystems/components, Ventilation subsystems/components and Air-Conditioning subsystems/components.

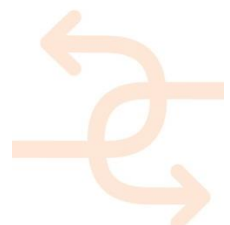

Infiltration and exfiltration

Infiltration and exfiltration are the unintentional or accidental airflow into or out from a building, typically through cracks in the building envelope. Infiltration is sometimes called air leakage. It is caused by wind, negative pressurization of the building, and by air buoyancy forces known commonly as the stack effect.

Initial commissioning

Covers the basic commissioning required to satisfy a building's specification. It is just proof of capability, such as the ability of a heating system to provide the required heat output.

Mechanical ventilation

Mechanical ventilation means ventilation provided by mechanically powered equipment, such as motor-driven fans and blowers, but not by devices such as wind-driven turbine ventilators and mechanically operated windows.

MEP worker

The MEP worker is used as a collective name for the plumber, electrician, and HVAC mechanic. These are the people that do the specialized work concerning the MEP systems., e.g. installing or adjusting MEP/HVAC systems and commissioning. For some activities, it is also thinkable that non-specialists will fill in. For example, to mount MEP components or to assemble pipes and ducts when they are integrated in a prefab building element.

Natural ventilation

Natural ventilation means ventilation provided by thermal, wind, or diffusion effects through doors, windows, or other intentional openings in the building.

Outdoor air

Controlled air entering the system or opening from outdoors before any air treatment.

Pre-Commissioning

Preparing the components and systems for commissioning. Pre-Commissioning activities overlap mechanical completion activities and start from component level to subsystems to system level. Activities include: checking for design conformity, checking the status of electrical, mechanical and instrument installations, running-in of equipment, flushing and cleaning activities.

Radiant Asymmetry

It describes differences in the thermal radiation of the surfaces surrounding a person that may cause local discomfort or reduce acceptance of the thermal conditions.

Return air

The return air is the air removed from a space to be then recirculated or exhausted.

Simulation-based diagnosis approach

Is a diagnosis approach estimating impact of performance deviations on KPI and total quality levels. The approach uses simulation techniques to simulate the mentioned impact.

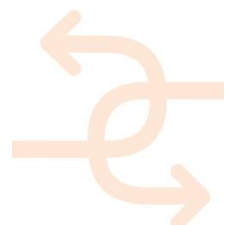

Sound intensity

Sound intensity also known as acoustic intensity is defined as the sound power per unit area. The SI unit of sound intensity is the watt per square metre (W/m^2). The usual context is the noise measurement of sound intensity in the air at a listener's location as a sound energy quantity.

Sound pressure level (L_p)

Sound pressure level (L_p) or acoustic pressure level is a logarithmic measure of the effective pressure of a sound relative to a reference value. Sound pressure level is measured in dB. The commonly used reference sound pressure in air is: $p_0 = 20 \mu Pa$. This is considered as the threshold of human hearing (roughly the sound of a mosquito flying 3 m away).

Supply air

Air flow entering the treated space, or air entering the system after any treatment. The supply air is made up of clean outdoor air and is sometimes mixed with or exists completely out of recirculated air.

Testing, Adjusting and Balancing (TAB)

A testing and adjustment of constructed and installed components and systems to ensure that the equipment and systems operate to meet the specifications written in the design documents. It includes adjusting water flow in pipes, air flow in ducts, and tuning control parameters.

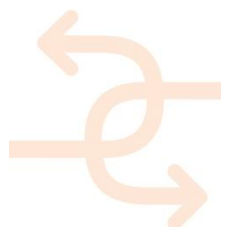
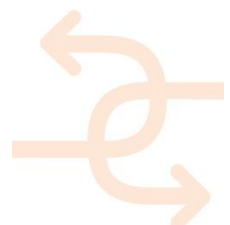
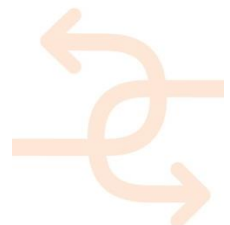

Table of contents

1. INTRODUCTION	17
1.1 Objectives and structure of this deliverable	17
1.2 R&D methodology employed to achieve results presented in this deliverable	18
1.3 Main achievements and limitations	18
1.4 Positioning of this deliverable	20
2. COMPLEXITY OF HVAC/MEP SYSTEMS	22
2.1 Factors influencing building quality	22
2.2 Levels of self-inspection	23
2.2.1 Inspection at the component level	24
2.2.2 Inspection at the subsystem level	25
2.2.3 Inspection at the system and building level	27
2.3 Total building quality and related KPI's	27
3. A NEW DIAGNOSIS APPROACH	29
3.1 The role of simulation techniques	29
3.2 Simulation based self-inspection	30
3.3 Integration in the INSITER methodology	34
4. HEAT PUMP SYSTEM	37
4.1 Measurement protocols and related variables	38
4.2 Real measurements and related devices	39
4.2.1 General procedure and considerations	40
4.2.2 Components of the heat pump system	41
4.2.3 COP of the heat pump	44
4.2.4 Test report on the measurements	45
4.3 Identification of difficulties	45
4.3.1 Limitations	46
4.4 Diagnosis and related KPI's	46
4.5 Thresholds and tolerances	47
5. VENTILATION SYSTEM	49
5.1 Measurement protocols and related variables	50
5.2 Real measurements and related devices	52
5.2.1 General procedure and considerations	53
5.2.2 Entire system measurements	54
5.2.3 Central system or appliance measurements	55
5.2.4 Ductwork measurements	59
5.2.5 Room measurements	60
5.2.6 Test report on the measurements	65
5.3 Identification of difficulties	65



5.3.1	Difficulties	65
5.3.2	Limitations	66
5.4	Diagnosis and related KPIs	66
5.4.1	Simulation based analysis	67
5.4.2	Thermal Comfort	71
5.4.3	Acoustic Comfort	71
5.4.4	Indoor Air Quality	72
5.5	Thresholds and tolerances	73
6.	SOLAR HOT WATER SYSTEM	74
6.1	Measurement protocols and related variables	75
6.2	Real measurements and related devices	77
6.2.1	General procedure and considerations	79
6.2.2	Generation systems	81
6.2.3	Intermediate heat exchange	84
6.2.4	Distribution components	87
6.3	Identification of difficulties	90
6.3.1	Scope of INSITER measurements and limitations of the inspection process	90
6.4	Diagnosis and related KPI's	92
6.4.1	Simulation-based self-inspection for solar hot water collectors	93
6.4.2	Practical application example of the simulation-based self-inspection approach	95
6.5	Thresholds and tolerances	98
7.	LIGHTING SYSTEM	100
7.1	Measurement protocols and related variables	101
7.2	Real measurements and related devices	103
7.2.1	General procedure and considerations	103
7.2.2	Measurements	104
7.2.3	Test report on the measurements	106
7.3	Identification of difficulties	107
7.3.1	Difficulties	107
7.3.2	Limitations	107
7.4	Diagnosis and related KPIs	108
7.4.1	Efficiency of electrical components	108
7.4.2	Visual Thermal Comfort	110
7.5	Thresholds and tolerances	110
8.	DISCUSSION AND CONCLUSIONS	111
8.1	Application of the new diagnosis approach	111
8.2	Limitations of the new approach	112
8.3	Total building quality and energy efficiency	112
	REFERENCES	113



1. Introduction

The INSITER project aims to increase building quality and optimizes energy performance in buildings. This optimisation is achieved by eliminating the gaps between design and realisation based on prefabricated components. The final INSITER solution will include:

- a new self-instruction process;
- a new self-inspection process;
- both processes supported by intuitive and cost-effective tools (Augmented Reality); and
- all connected through the BIM process and empowered by simulation and monitoring software.

1.1 Objectives and structure of this deliverable

The main objectives of this deliverable are:

- to implement calculation and simulation methods (such as TRNSYS and VABI Elements) and monitoring techniques (such as Simaxx) in the self-inspection process;
- to estimate the uncertainty of each key performance parameter measured on the global building performance;
- to extract self-instruction information as guidelines for the construction workers; and
- to embed the new self-inspection processes in the quality assurance systems and standardization.

The deliverable is organized in eight main sections. Each section introduces different topics related to each other as it follows.

- **Section 1** introduces the deliverable's objectives; the structure of the main contents and relations; the methodology adopted to achieve the results presented and the research limits.
- **Section 2** explains the complexity of the HVAC/MEP systems, related to the self-inspection process for quality assessment.
- **Section 3** introduces the new approach for the self-inspection methodology of the MEP/HVAC systems.
- **Section 4** applies measuring and calculation solutions (including the new approach) to the heat pump system.
- **Section 5** applies measuring and calculation solutions (including the new approach) to the ventilation system.
- **Section 6** applies measuring and calculation solutions (including the new approach) to hot water solar system.
- **Section 7** applies measuring and calculation solutions (including the new approach) to lighting system.
- **Section 8** provides discussion about the new approach/solutions and draws conclusion on the whole provided work of D1.7.

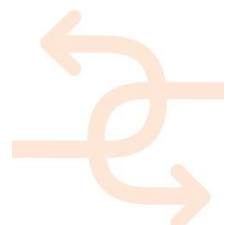

1.2 R&D methodology employed to achieve results presented in this deliverable

This deliverable presents the main results of the research for integration of calculation and simulation techniques to support the self-inspection process including the related decision support process.

The R&D methodology is based on the following:

- experience by the consortium partners and especially of Task 1.3;
- new processes in the field of Commissioning;
- new possibilities in the world of digital construction (using BIM and simulation techniques); and
- new developments in the field of quality control software (such as BIM Field360 and ED-Controls).

The development of the calculation solutions and diagnosis approach has been done through answering the following questions:

- What is the current practice of inspection process?
- Which part of the inspection process is relevant to and can be transferred to the workers themselves?
- Which information does the worker need to perform the inspection process?
- Which tools can support the worker performing the inspection?

The global planning and process that is followed is shown Figure 5.

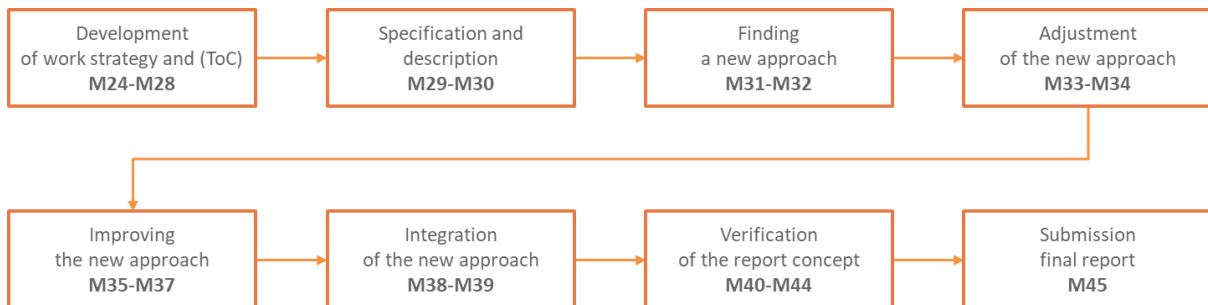
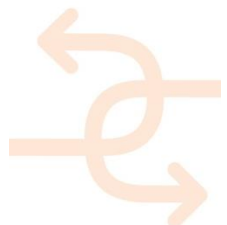

Figure 5: Project planning T1.3 / D1.7

1.3 Main achievements and limitations

The deliverable presents the results achieved by T1.3 during the third and fourth years of the INSITER project that can be summarized in:

- **Explaining the complexity** of the interaction between the MEP/HVAC systems in relation to the total building performance;
- **Extending the self-inspection process**, by introducing measuring and calculation solutions to the process developed in D1.6;
- Introducing a **new simulation based self-inspection approach** to support self-inspection methodology; and
- **Specifying the new solutions and approach** for the **four major HVAC/MEP**.



The T1.3 team was able to cover all D1.7 objectives as required in the Description of Action. However, some difficulties were also faced during the project resulting in some limitations. The following table presents limits faced during our work on D1.7.

Topic	Limit
1. Actual total building performance	Actual performance of the building is a function of several factors including: design & building elements, HVAC/MEP systems, use & users and finally weather conditions. The INSITER methodology contributes to increasing total building quality and energy efficiency by providing measuring and diagnosis solutions for inspecting HVAC/MEP systems. However, the INSITER self-inspection process is not able to indicate the actual performance of the building during the construction stage (scope of the INSITER project). Only monitoring techniques (using actual data from the building, HVAC/MEP system and weather condition) are able to provide insights about the whole performance. At least after one year (four seasons) of data collection and analysis. The monitoring stage and needed four seasons are outside the scope of the INSITER project.
2. Preventing common errors and increasing building quality	It is very clear that preventing (common) errors during the construction is resulting in higher building quality and lower rework cost. D1.7 is also able to quantify the impact of the (to be avoided) errors. But it is impracticable to quantify the performance increase created by the INSITER method during the period of the INSITER project. To do that, you have to execute the project twice using two processes: the traditional one and the INSITER one.
3. Fully self-inspection process	It is very desirable to transfer the quality issues and inspection processes to the workers. However, from a practical point of view there is still need to have overall control on the inspected/controlled work. The role of the commissioning manager is, practically, irreplaceable.
4. Aggregation of performance deviations	It is very feasible to, theoretically, estimate the impact of a performance deviation on the whole performance of the building. We use the new approach based on simulation. This is only possible if we consider that all other building elements and HVAC/MEP systems are performing as designed. From practical point of view is that unrealistic! In practice, it is unimaginable that only one deviation will find place.

Table 1: research and result limitations of D1.7

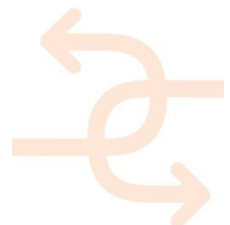

1.4 Positioning of this deliverable

This document, D1.7, is the second deliverable of task 1.3. For development, it relies on the input from some of the deliverables from other tasks, and consequently, its output will be used in, again, in WP6 (for training purposes). This is shown in Figure 6. Generally, task 1.3 will develop the methods for MEP/HVAC components as task 1.2 is doing the same for building envelop. The input includes the generic methods, software and hardware development and the research done on simulation and BIM. De developed methods will be tested and demonstrated in WP5, and feedback will be provided. The development of training material and standardization will be based on the input from T1.2 and T1.3.

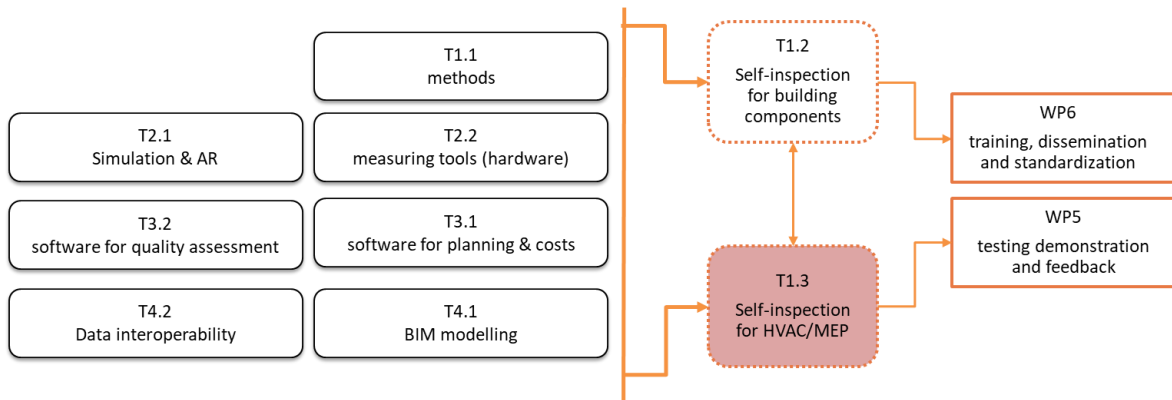

Figure 6: Input and output of task 1.3

As D1.7 is developed in T1.3, D1.5 is synchronically developed in T1.2. Because of the similarities, the approach is equal. The content differs though, because of the differences between MEP/HVAC systems and building elements. In Figure 7 the difference between D1.5 and D1.7 is shown, mainly concerning the 'simulation based approach for the measuring and diagnostic solution for the HVAC/MEP systems.

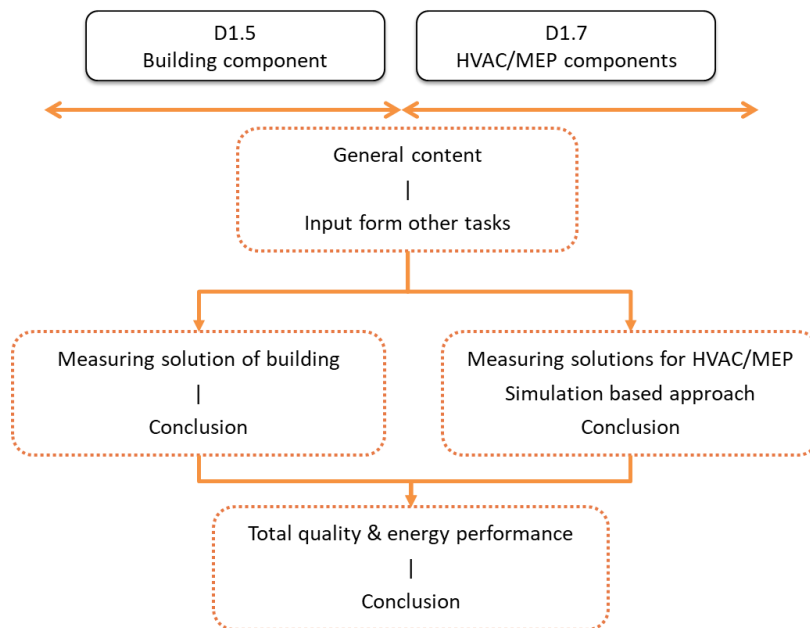
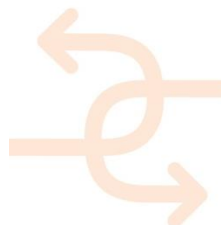

Figure 7: Development of and difference between D1.5 and D1.7



Finally, within T1.3 two deliverables are developed: the present D1.7 and D1.6. Where D1.6 ended D1.7 began focussing on new approach for calculation and diagnostic solutions for inspection HVAC/MEP systems. See Figure 8 for a visual explanation.

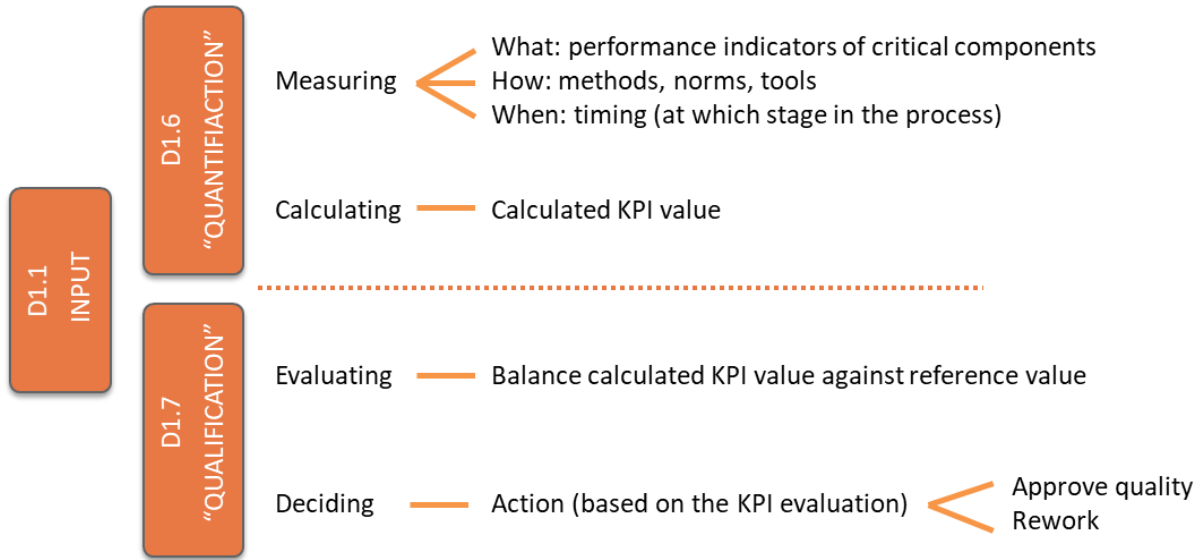
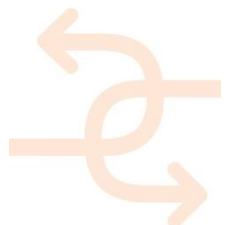

Figure 8: Inspections for MEP/HVAC components during the different building phases



2. Complexity of HVAC/MEP systems

Buildings we realize are getting better, smarter, and more connected. Current buildings go beyond offering only basic services. Buildings have to meet high levels of aesthetic requirements, user needs and expectations and to meet the building code (regulations). All of this has to be done considering high levels of sustainability and return on investment.

To achieve all these requirements Heating, Ventilation, and Air Conditioning systems (HVAC) and Mechanical, Electrical & Plumbing (MEP) have to work and interact with each other and with the building envelope in a proper way. HVAC/MEP systems cover the whole range of building services. Building services take care of creating comfortable, healthy and safe indoor environment in buildings. They also organize our use of the building including building access and security. In more complicated situation, building can also organize and steer our daily work; activity based.

To ensure that building elements and HVAC/MEP systems perform properly, a central Building Management System (BMS) has to be implemented. It is the brain of a building. A BMS gets information from rooms, systems etc. by means of sensors. Based on beforehand designed strategies, the BMS's control the building including space heating & cooling, lighting, ventilation etc. In short, all building elements and HVAC/MEP systems are working together to ensure the required performance of a building.

2.1 Factors influencing building quality

There are many factors influencing the total (actual) building quality and energy performance (see Figure 9). The most important factors are:

- the building envelop including facades, windows, walls etc.;
- the HVAC/MEP systems including heating & cooling generation, distribution and supply;
- use & user profile including building occupancy, activities to be performed in the building, number and type of appliances etc.; and
- weather conditions

Each of these factors can positively or negatively influence the total quality of the building or the energy performance. Besides, building and HVAC/MEP can strongly influence each other in terms of energy efficiency. Here below some examples are listed:

- Deviations in quality of building elements (e.g. lower R_c -value or higher air infiltration) may cause higher energy demand and therefore higher energy consumption by the heat pump.

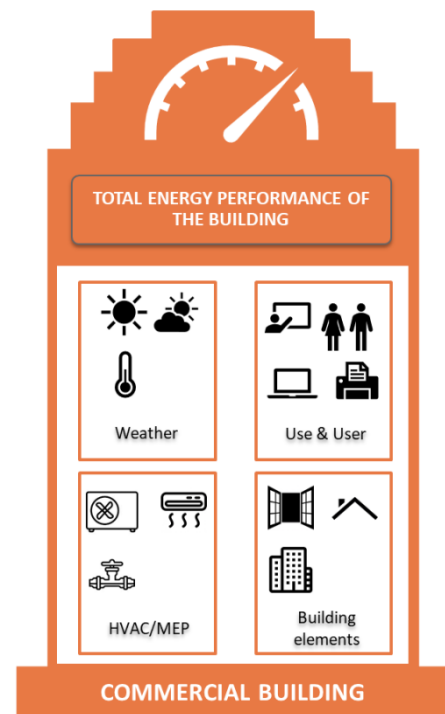

Figure 9: Illustration of factors influencing the total quality performance of a commercial building



Inspection level	Inspection aim	Action and tolerance
Damages and pollution I & II	Quantity check: visual inspection for quantity and damage	Damaged or polluted components should be replaced if repair or cleaning is not possible.
product identification I & II	Quality check: comparison to the specification in BIM	In case of deviation (negatively influencing the performance), the component should be rejected if performance specifications are lower than designed.
Self-inspection protocols I & II	Functionality check: comparison to the specifications in BIM	In case of performance deviation, the component should be replaced if performance specifications are lower than designed. In case of setting deviation, the component should be fixed.
Measurement and calculation	Performance check: comparison to the design specifications and expected performance output	Performance deviations should be evaluated according to agreed values and tolerances.
Monitoring	Performance check: in real use conditions (weather and occupancy for a long period (one year after delivery))	Performance deviations should be evaluated according to agreed values and tolerances.

Table 2: levels of inspections in relation to commissioning

2.2.1 Inspection at the component level

The most components of the HVAC/MEP systems are mass-productions products. Valves, pipes, filters, sensors and pumps are mass produced components. The production process of these components is further developed. A lot of inspection and quality control work takes place in the factory ensuring high levels of certainty of performance (5-A/B). It is clear that rejected components in the factory will not be used.

Self-inspection of a component, as a stand-alone part, is perhaps the most well-understood form of inspection (see Figure 11). Besides to the factory acceptance test, on-site self-inspections will be performed including product identification and damages/pollution inspection. These first and second levels of self-inspection ensure that the component is capable to perform in the right way. This is of course a basis requirement for well-functioning whole system.

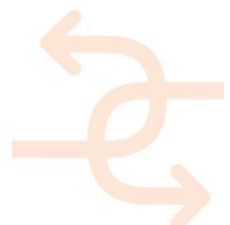

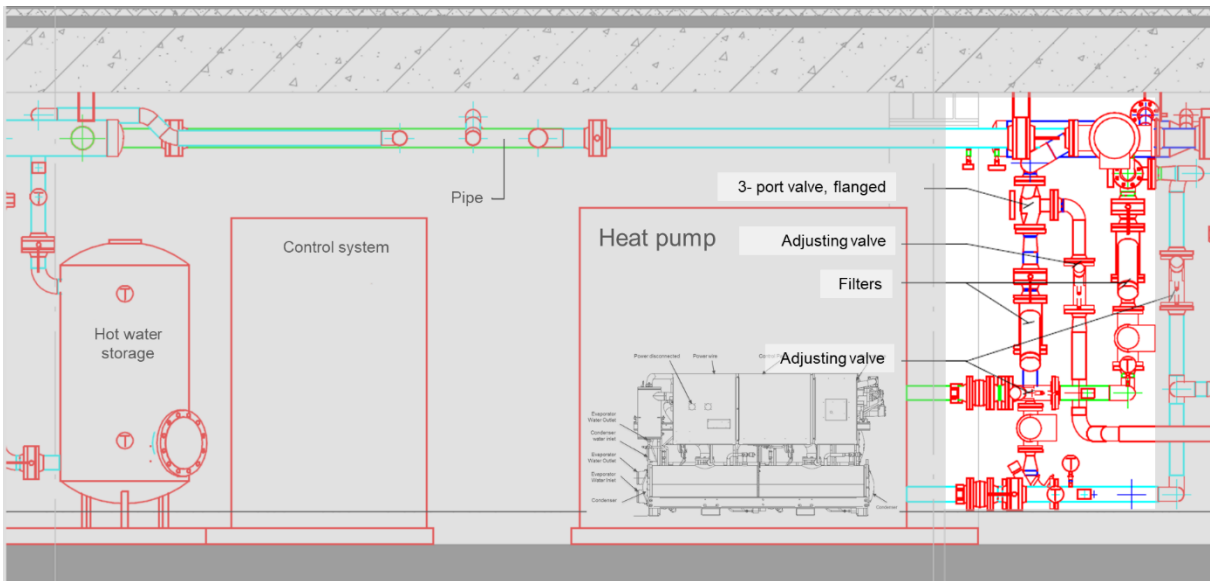

Figure 11: visualisation of individual components as part of a heating system

The third level of self-inspection ensures that components have been properly mounted having the right settings (e.g. opening position of a valve). The third inspection level ensures also, to accepted levels that the components, in this example as a part of the distribution circuit, will properly interact with the other components. This is also a basic requirement for well-functioning whole system.

2.2.2 Inspection at the subsystem level

A subsystem is a set of interacting and interdependent components, forming a system itself, but also acting as a component of a larger system. Examples of subsystems are heat pumps, hot water storage and distribution circuit as parts of a heating system. Subsystems are traditionally fully produced in the factory and installed on-site (heat pump). Some subsystems or their components like piping and duct systems can be (partly) prefabricated. Figure 12 shows some subsystems of a heating system of a commercial building.

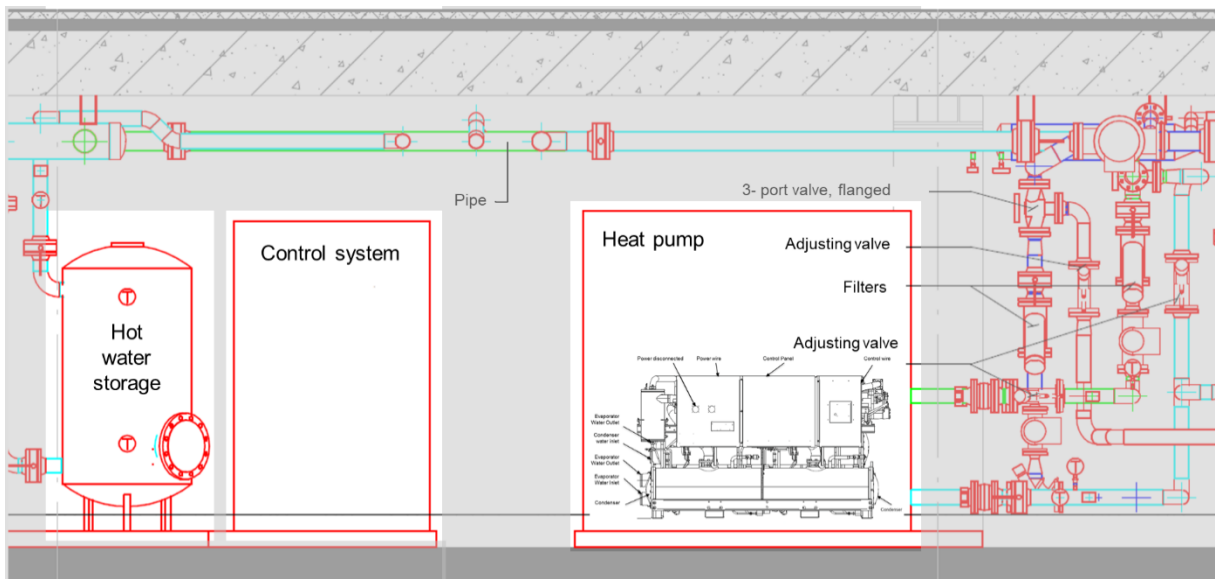

Figure 12: examples of subsystems of a heating system in a commercial building



Self-inspecting of subsystems covers:

- Quantity self-inspection: product identification ensuring the right product is mounted;
- Quality self-inspection: product is not damaged; and
- Functionality self-inspection as part of the site acceptance test.

The self-inspection at the functionality level depends on the way subsystems have been produced. Mass-produced subsystems such as heat pumps are inspected in the factory and installed on-site by an expert team including experts from the manufacturer, a mechanical engineers and an electrical engineer. These systems get also inspected by the expert team. The result of the first inspection is a factory acceptance test FAT and the result of the second inspection is a site acceptance test SAT. Reports of both tests are delivered and saved. However both tests are done due to the factory conditions and to the design parameters and not to the actual use conditions of the building.

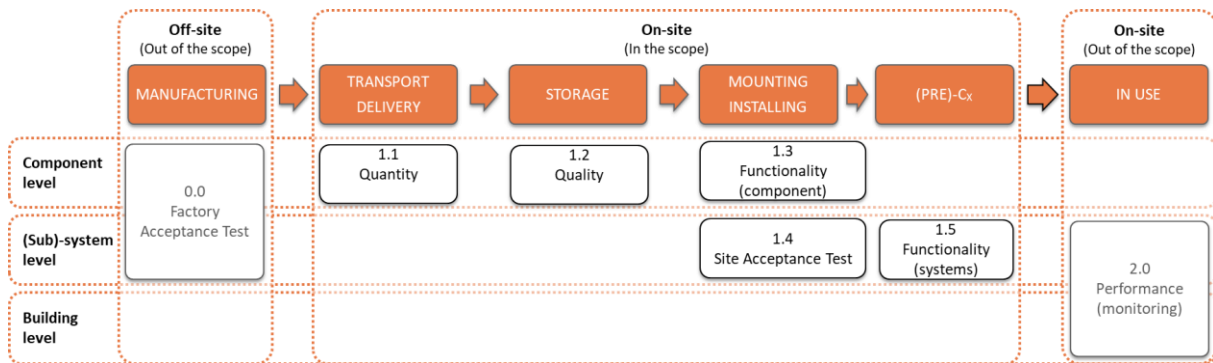
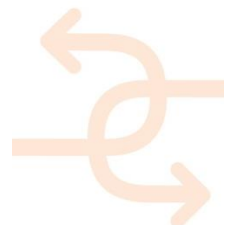

Figure 13: several inspection processes for several levels of components and subsystems

The most interesting elements of the actual inspection of such subsystems is if these systems will mutually interact in the right way and ensure the delivery of the requested performance. This is a process that takes place after the building delivery and covers long period of monitoring. In sections 4, 5, 6 and 7 performance measurements for the heat pump systems, ventilation systems, solar hot water systems and lighting systems, respectively, will be presented.

In relation to performance measurements, construction and HVAC/MEP workers have to have information and tools to support their decision making process during the self-inspection process. They have to be able to decide if measured performances (and possible related deviations) could be accepted or not. Also to decide on the impact of that deviation on the actual building performance. Following deviation tolerance percentages doesn't respond to the actual situation as buildings differ in almost all specifications of buildings envelop and HVAC/MEP systems. This means that performance deviations in a specific element/component could have different impact on the actual building performance. To overcome this challenge, we introduce a new approach in Chapter 3.



2.2.3 Inspection at the system and building level

Self-inspection by workers at the system level and the building level is perhaps the most complicated stage of the quality control process. After self-inspecting all components and subsystems including quantity, quality and functionality issues, workers have to ensure that the components, subsystems and systems will, in its entirety, properly perform according to the design and the building demand. This also means that the brain of the building, the Building Management System, will properly control the HVAC/MEP systems in actual situations.

There are two important challenges for self-inspecting at this stage. First, the INSITER project is about the self-inspection process during the construction stage as the workers are installing/mounting the components and subsystems. In that stage the HVAC/MEP systems are not completed yet and therefore self-inspection of performance at this level is difficult and is limited to the connection, joint, ductwork etc. Second, as the building is not completed and not occupied yet, there is e.g. no heating, cooling or ventilation demand from the building. In this case, HVAC/MEP cannot be inspected in real conditions. For this reason, real conditions should be mimicked by creating e.g. a virtual situation having building users and heating demand. The real performance inspection for the whole building and its HVAC/MEP systems is in the use phase. In the use phase, real sensor data and meter measurements are used to analyse building performance (using performance monitoring techniques like Simaxx).

In the current practice, the Commissioning authority is in charge for this inspection stage. It is for this reason outside the scope of the INSITER project. However, in Chapter 3, we will try to adapt some scenario based and monitoring techniques in the new approach.

2.3 Total building quality and related KPI's

In early work done for D1.1, D1.4 and D1.6 we agreed on a set of KPI's covering the most important quality issues of building. The list concerns two groups of KPI's: Energy Efficiency and Indoor Environment Quality, see Figure 14. KPI's related to Energy Efficiency has been grouped in four sub-groups covering the whole energy process: generation, transfer, distribution and storage. For the Indoor Environment Quality, four KPI sub-groups have been defined including: indoor air quality, Acoustic Comfort, Visual Comfort and Thermal Comfort. Based on Section 3 from D1.6 we defined very specific measurement fields that contribute to the whole building quality. Although total quality is top-down defined, performance measurements and self-inspection processes will be discussed bottom-up. Figure 14 will be adjusted for each studied HVAC/MEP system indicating available and executable performance measurements.

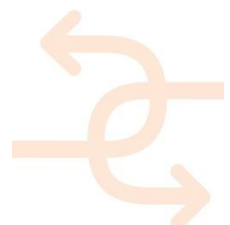

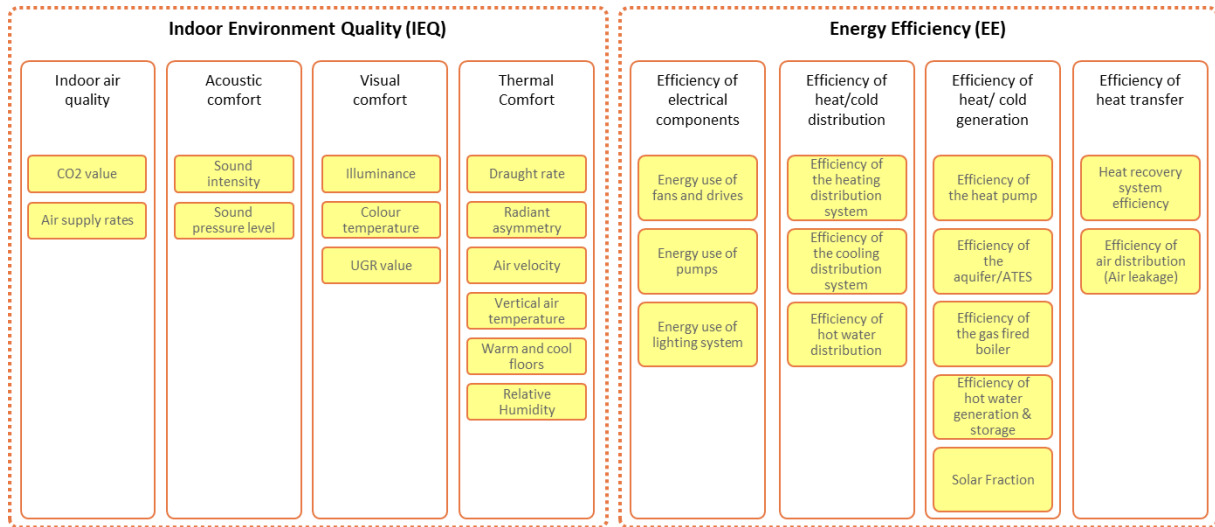
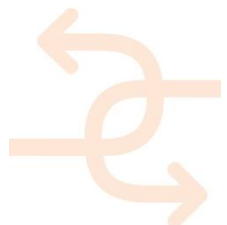

Figure 14: overview of used KPI's for HVAC/MEP systems



3. A new diagnosis approach

The INSITER approach focuses on transferring the inspection responsibilities to construction and HVAC/MEP workers during the construction phase creating a so-called self-inspection process. The new INSITER methodology should at the same time ensure that the self-inspection is going through a smooth process without adding extra work load to the workers. Such a transfer should attentively be organized and prepared. Workers will get equipped with well-structured process, measurement devices and decision making tools/information to support taking the right decision. All this is going through a BIM process.

In the previous sections, the self-inspection methodology is discussed on the several levels of the HVAC/MEP systems introducing some difficulties of self-inspection in relation to current practices. This Chapter is introducing a new approach to support the self-inspection at the functionality level for systems and subsystems.

3.1 The role of simulation techniques

Simulation techniques, simulation software or building performance simulations are software to predict and evaluate one or more performance aspects of a building and its related HVAC/MEP systems. Simulation software aims at creating a virtual model of the building that is sufficiently accurate to form a useful representation of the actual building. Current simulation software covers a long list of building performance aspects including:

- *Indoor climate*: ambient air temperature, relative humidity, solar radiation and comfort levels.
- *Energy*: internal energy gains, energy consumption and generation of renewable energy.
- *Distribution circuit*: hydraulic installation designs.

The input for simulation software differs according to the simulated performance aspect. Generally speaking, detailed geometric and HVAC/MEP information are the input for simulation software. In D3.3 detailed information were reported about simulation software in relation to the purpose of the INSITER project including VABI Elements, TRNSYS and Hysopt. For practical issues, we only focus on VABI Elements in the next sections to explain the new approach. To be clear the most simulation software can be used for the new approach. In Chapter 6 we applied TRNSYS for the simulation-based inspection for the solar hot water system. This is due to the experience of CARTIF with this specific simulation software.

VABI-elements is a dynamic building performance simulation tool to simulate the buildings performance in which the installations are coupled to the building. Besides hydraulic systems, VABI-elements contains modules for ventilation, cost, and planning. A connection to BIM is available where the building geometry is imported using the an IFC file. Simulations have a low level of detail and can be performed in an early design stage, for example, when the installation concept is known or developed. The building is represented by a three-dimensional model of the building geometry including materials and their properties. Installation concepts are selected and control strategy must be entered. When performing a simulation for a building all building and HVAC/MEP details will be used to simulate the performance of the building. Changing one or more details or parameters will result in new performance output. The new approach will be based on this functionality.

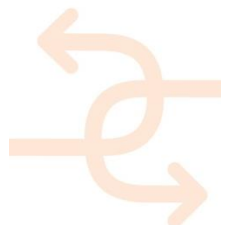

TRNSYS¹ is a simulation software used in the fields of renewable energy engineering and building simulation for passive as well as active solar design. It originates from the application of performing dynamic simulation of the behaviour of a solar hot water system for a reference meteorological year so for the purpose of lifecycle cost analyses.

Imagine that we adjust the U-value of an external wall mimicking an inspected deviation in the building façade, or adjusting the COP of a heat pump mimicking lower delivered performance during the use of the building. Re-simulating the building will perhaps result in a new performance level: higher energy consumption levels or lower levels or higher levels of CO₂ production. The difference between the two levels of performance is the performance deviation caused by the inspected deviation. Repeating this work for several deviations levels can result in a graph presenting the relationship between measured deviation and simulated performance deviation. Such a graph can be used by workers to understand the impact of measured deviations and support the decision making process during a self-inspection process. In some cases, there is no need for complicated simulations as simplified calculations can help creating such a graph. Figure 15 illustrates the use of simulation software in generating graphs of performance deviations. Hereafter we will call it a sensitivity analysis.

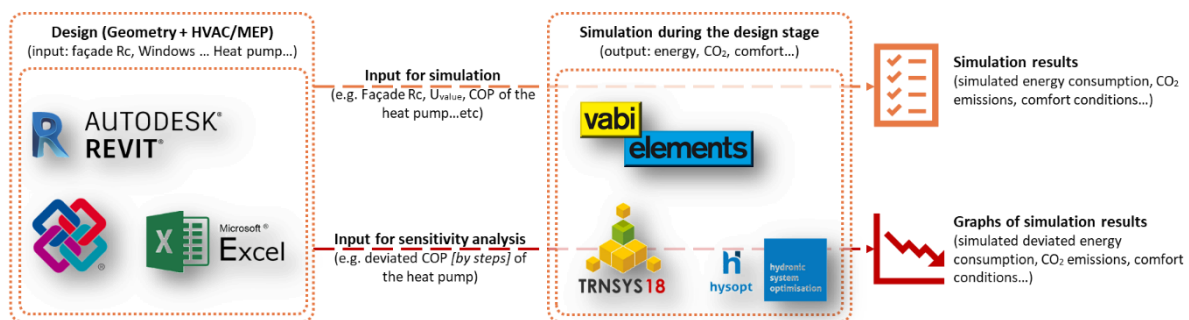

Figure 15: illustration of the role of simulation software in the sensitivity analysis

In the next sections the new approach will be presented and discussed as a part of the whole self-inspection methodology.

3.2 Simulation based self-inspection

Self-inspection by workers at the functionality and the performance level requires that workers can understand measured deviations and can be able to make the right decision about accepting or rejecting the inspected subsystem in case of deviation. Especially the impact of a measured performance deviation on a KPI or total building quality is a hard issue. The following steps present the simulation based self-inspection approach that fulfil the needs of the workers during the self-inspection process. In order to better follow the approach, examples related to energy consumption as KPI will be used.

¹ <http://sel.me.wisc.edu/trnsys/>



1 Starting point; understanding building performance and major influencing systems

As discussed in Section 2.1, energy efficiency of buildings depends on several factors including building envelop (design, orientation, occupation, etc.) and HVAC/MEP systems. It means that different buildings have different energy consumption patterns. In other words there are different shares of energy consumptions for space heating, cooling, lighting etc (see Figure 16).

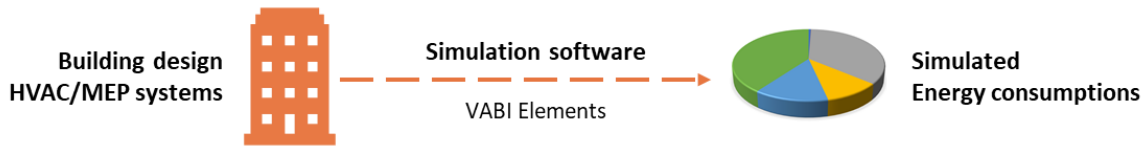

Figure 16: understanding energy consumption pattern by energy simulation

Figure 17 shows energy consumption patterns of two different commercial buildings. The building at left has a bigger energy share for lighting in relation to cooling and heating. This is because of the building year, use of traditional lighting systems. The building at right shows a different energy consumption pattern having a bigger share of energy consumption for space heating in relation to lighting. Understanding this kind of energy consumption patterns can help building designers and quality inspectors to pay extra attention to subsystems and systems that directly or indirectly influence energy efficiency.

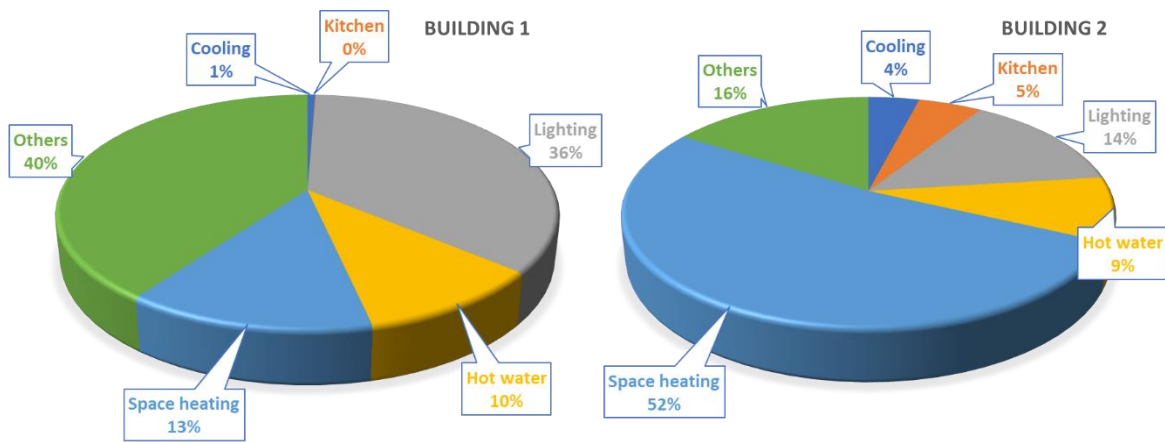
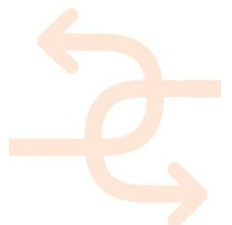

Figure 17: comparison of energy consumption patterns between two different commercial buildings

2 Re-prioritizing lists of common errors and critical components

D1.6 introduced lists of common errors and critical components for building elements and HVAC/MEP systems. In those lists, common errors and critical components had the same priority in the self-inspection process. However, based on Step 1, common errors and critical components may get different priorities according to their impact on the examined KPI. For example, additional attention can be paid on lighting systems if simulations reveal that lighting the major energy consuming systems in the building. However, this doesn't mean that other systems are less important.



3 Setting up a simulation strategy

In this step we first select the KPI's in question. Based on Step 2 and output from D1.6, we indicate which measurements should be performed during the self-inspection process, and more specific, to determine which input and performance output is related to those measurements. At the end of this step, we create a list of measurements (performance output) and related input parameters to be simulated next step; see Figure 18. Examples of high prioritized measurements are the COP of a heat pump or the efficiency of a ventilation system.



Figure 18: illustration of creating measurements to be simulated

4 Simulating performance deviations

In Step 3 we created lists of prioritized measurements to be performed during the self-inspection processes. The values of these measurements are actual performance of the specific component or subsystem. If all installing and mounting processes went well, this actual performance should be equal to the design performance; as-designed = as-built. In the case of performance deviation, workers have to quantify the impact of performance deviation on the related KPI and finally on the building quality. They need information (graphs) about the relationship between measurement deviations and performance deviations. By using that, they are able to properly evaluate the deviation and taking the right decision: accepting the deviation or rejecting it. For this purpose, performance deviation graphs should be created using the simulation software: a kind of simulated performance deviation. Figure 19 illustrates a performance deviation graph. Let's take the heat pump as an example. We know that heat pump is a crucial part in the heating system. The Coefficient of Performance (COP) of the heat pump is a good indicator for the performance of the heat pump. In the construction phase and right during the installation of the heat pump it is very hard to quantify the impact of possible COP deviation on the Energy Efficiency as a whole indicator for building quality. In this case, we are going to measure the COP of the heat pump. We will use the simulation software to create a graph presenting the relations between the COP deviation and the total energy consumption.

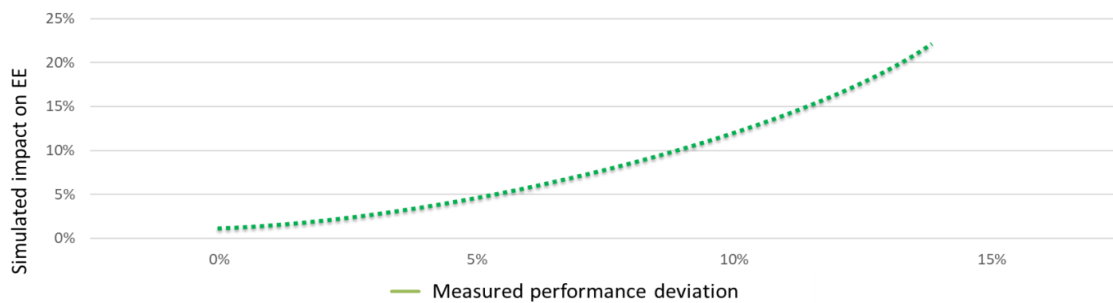

Figure 19: A graph illustrating the relationship between measured performance and simulated impact on performance



5 Determination of thresholds

After simulating the relationship between measured performance and its impact on actual KPI performance, it is essential to agree on the boundaries in between deviations are accepted: **thresholds**. Manufacturers prescribe maximal accepted performance deviations (thresholds) for their products (components or subsystems). However, those thresholds consider optimal test conditions (usual factory conditions). Performance deviations below prescribed thresholds can have large impact on actual performance. Especially in the case that several, may be aggregated, performance deviations can simultaneously take place. For this reason, building designers together with commissioning experts have to agree and indicate the boundaries in between performance deviations could be accepted by the workers during a self-inspection process. Figure 20 shows that, for example, a performance deviation of 6% is the maximum to be accepted as it results in 5% deviation in the Energy Efficiency (EE).

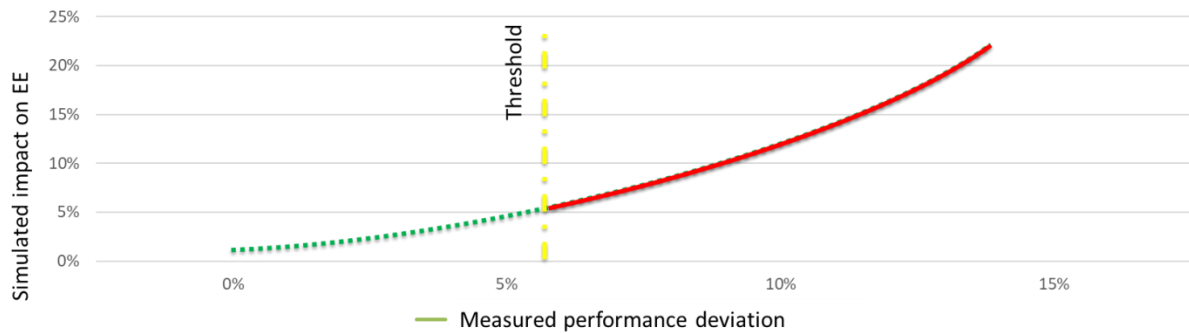
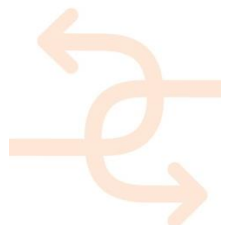

Figure 20: illustration of a threshold based on a simulation approach

This approach will be applied for the heat pump systems (Chapter 4), the ventilation systems (Section 5.4), the solar hot water system (Section 6.4) and ventilation system (Section 7.4).



3.3 Integration in the INSITER methodology

The presented approach in Section 3.2 adds new level to the self-inspection process of the INSITER methodology, see Figure 21. Especially for mass-production components and subsystems, this approach is complementary to the factory acceptance tests performed by the manufacturers off-site. The new approach considers a functional test into somewhat actual test conditions. Together with the quantity and quality check, see Figure 22, performance gap between design and realisation, as main goal of the INSITER project, can be ensured.

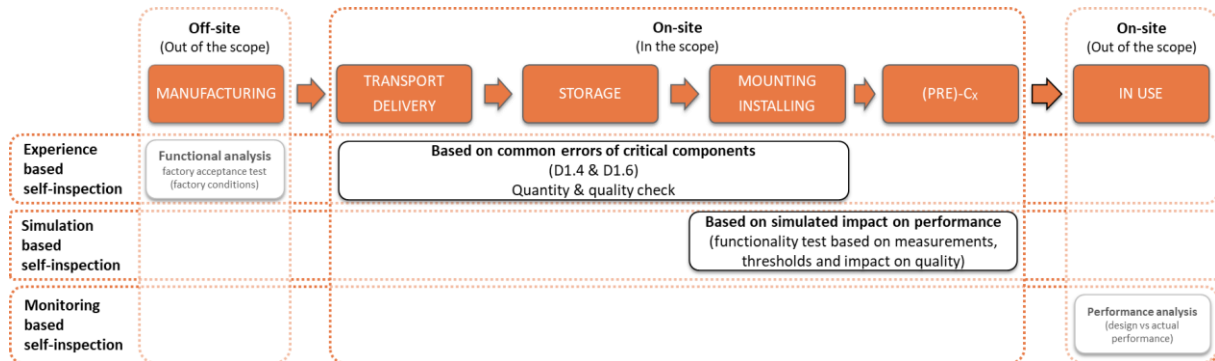
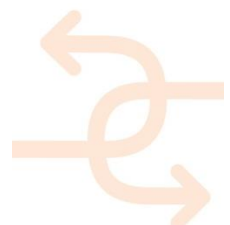

Figure 21: several levels and types of inspections in the different phase of construction

Workers benefit, during self-inspection processes on-site, from already created lists of common errors and critical components. These lists are based on experience of the consortium partners. Following the new diagnosis approach, the mentioned lists get better and more relevant as errors and components could be prioritized according to KPI's. The preparation for this diagnosis approach starts in the design stage using simulation software (in not complicated cases, calculations can be substitute simulation software).

To summarize, the INSITER methodology includes checks and measurements that are being carried out on the MEP/HVAC systems, in the following given order (see Figure 22): a) Completeness checks, b) Installation checks, c) Functional checks and d) Functional measurements.



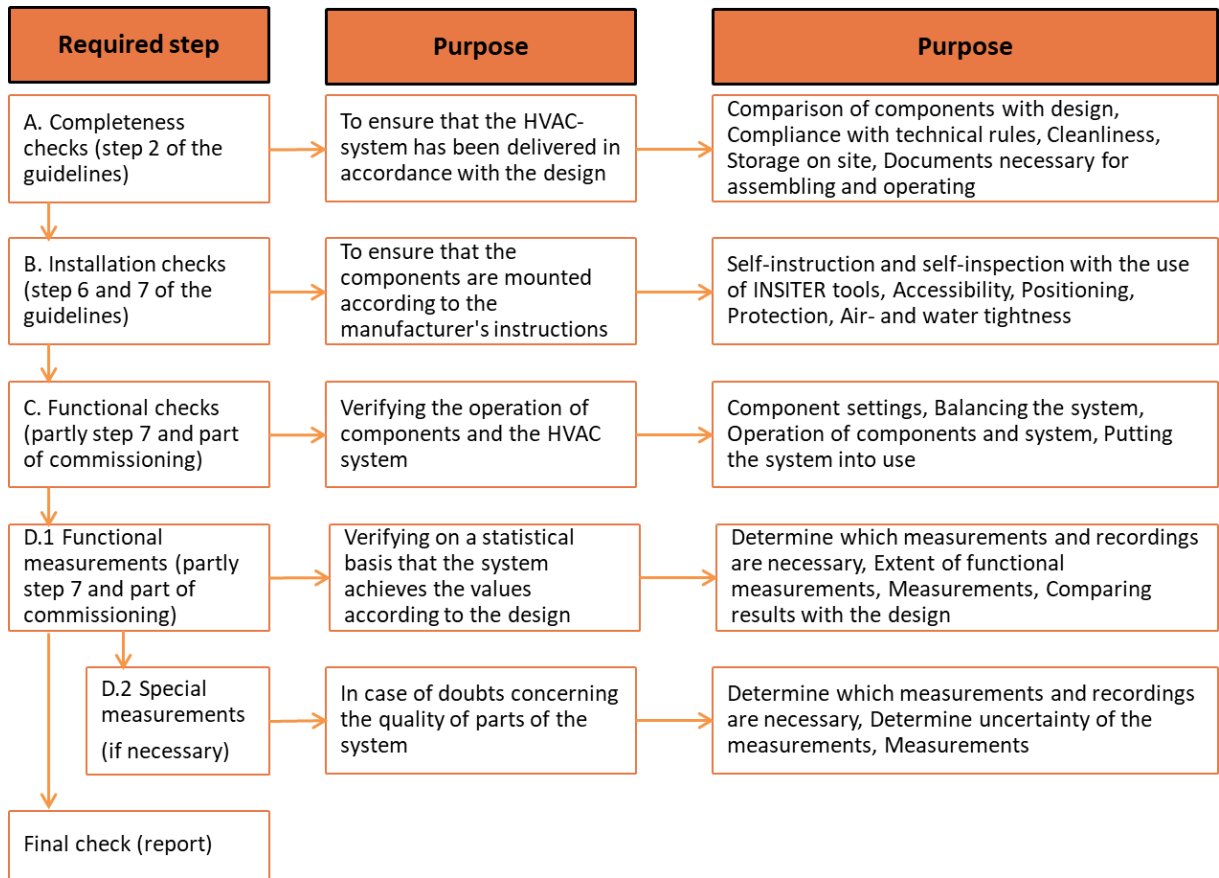
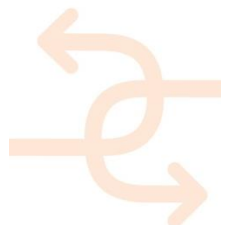

Figure 22: Summary of test and measurements, based on the approach



The integration of the new approach and the 8-steps in Figure 22 is illustrated in Figure 23.

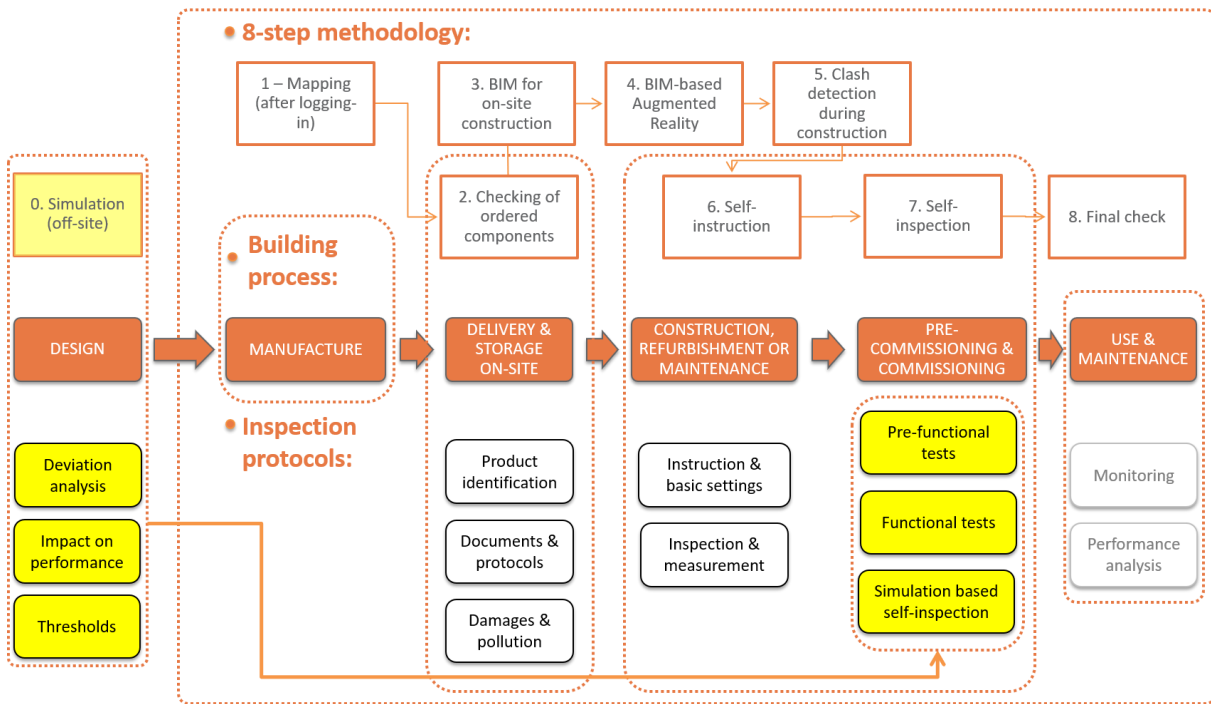
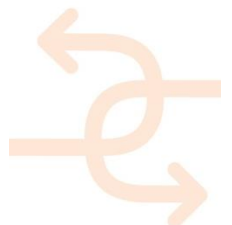

Figure 23: the new diagnosis approach in the INSITER 8 -steps methodology



4. Heat pump system

As discussed in Chapter 2.1, the energy performance of a heat pump system depends on the individual performance of the components the system consists of. These components are (see Figure: 24):

- Heat pump (Compressor, evaporator, expansion valve and Condenser);
- ATEs (aquifer thermal energy storage); Gas-fired boiler; Distribution circuit including a large number of valves, pumps, pipes, filters, Buffer tank; and Control system.

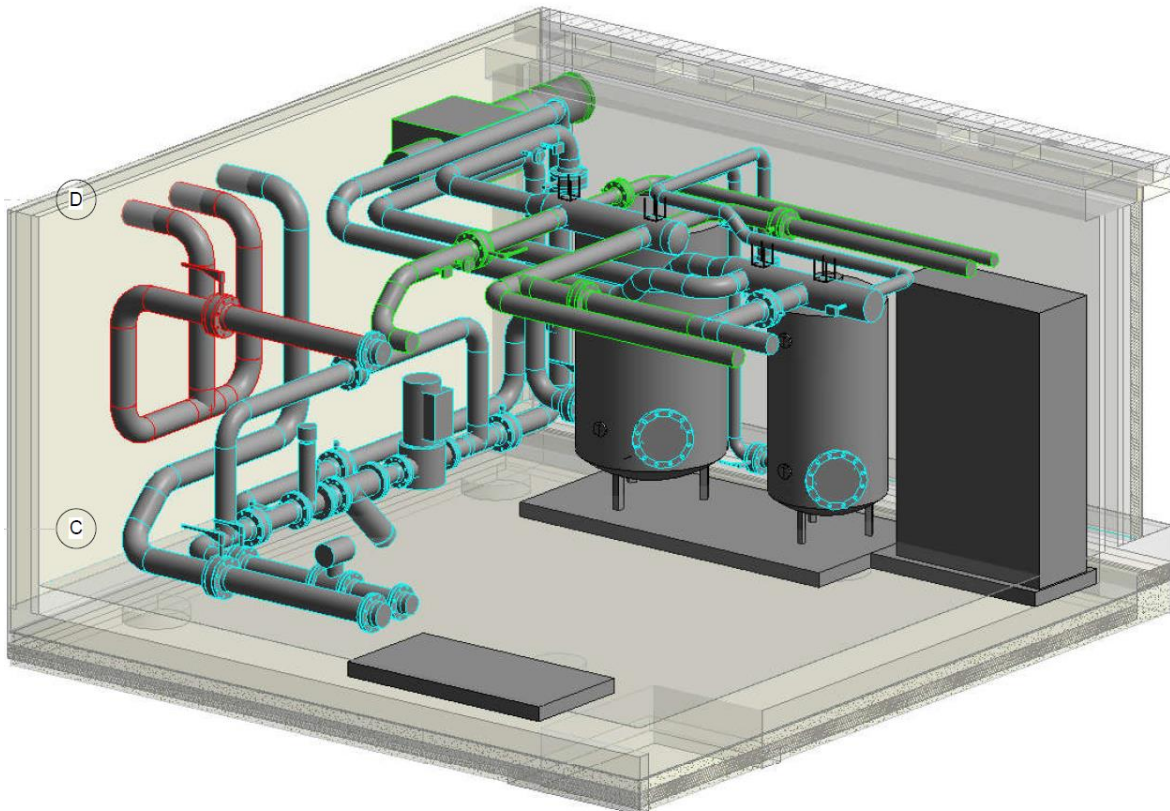
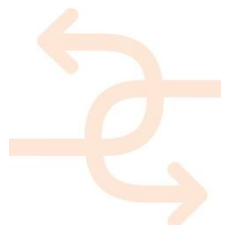

Figure 24: illustration of a technical room including parts of a heat pump system

The gas-fired boiler, heat pump, hot water storage (buffer tank), valves, pipes and filters are mass produced components. The production process of these components is further developed. A lot of inspection and quality control works take place in the factory ensuring high levels of certainty of performance. Because of the different system characteristics, system layout and demands of each building the distribution circuit and control system are designed especially for each building. The distribution circuit and the control system are most sensitive to errors because they are custom systems, designed especially for one specific building. Errors mainly occur during the administering of the correct settings of the components and cooperation of components through the control system.

In the most cases, heat pump units get installed by a dedicated team including experts from the manufacturer, an electrical engineer and a mechanical engineer. The team is also charged with the site acceptance test (SAT) which means that the heat pump is properly installed.



4.1 Measurement protocols and related variables

The purpose of the functional measurements is to give proper assurance that the system achieves the design conditions and set points as specified. In INSITER we defined a set of KPIs related to the energy efficiency (EE) and indoor environmental quality (IEQ). Based on Table 5 in D1.6, a dedicated KPI's list and related measurement protocol have been listed in the table below. Each of these KPIs will be validated by measuring the relevant values, in order to be able to evaluate the quality of the delivered work. Table 3 presents those specific KPIs and measurement protocols concerning the heat pump system.

KPI	Measurement protocol	Units	Description
Efficiency of heat transfer	Heat recovery system efficiency	%	It describes the amount of energy that is transferred from the primary to the secondary side as a percentage of the theoretical maximum where the secondary outlet flow equals the primary inlet flow. Determining the efficiency required measurement of the temperature difference over both the primary side and secondary side, together with the flow rate through both the primary and secondary side.
Efficiency of heat/cold generation	Efficiency of the heat pump	COP	COP is a measure of efficiency calculated by dividing the provided heat power by the consumed electric power. The COP depends on the temperature difference between supply and return temperatures of the distribution network and differs depending weather the heat pump works at full or partial load. The COP should be specified by the manufacturer both in full load and at partial load.
	Efficiency of the aquifer / ATEs	COP	SPF is a measure that relates the supplied heating and cooling energy to the consumed electrical energy or equivalent gas energy, like the COP for a heat pump. The difference is that in the Seasonal performance factor all systems related to the Heat pump system and ATEs are considered. For example, source pumps and dry coolers for regeneration of the cold source. Heat Generation of a gas-fired boiler is not taken into account because there is no direct relation to the ATEs.
	Efficiency of the gas fired boiler	%	When a gas-fired boiler operates at optimal conditions, the efficiency will be close to the predictions made during simulations. Efficiency of gas boiler depends on the operation and load profile. The efficiency of the gas-fired boiler can be determined using the used amount of gas measured on a flow meter in the gas pipes and a delivered power using temperature difference and flow over the boiler.
Efficiency of electrical components	Energy use of pumps	kWh	Electricity use of the heat pump depends on the operating load and delivered energy. Therefore, COP of a heat pump is a better indication to the performance of the pump.
Thermal Comfort	Air temperature in the room	°C	The air temperature in a room is measured and compared to the set point for indoor temperature that applies to that room. The heating and cooling system should be able to keep the room on the set point temperature during different weather conditions both at very high of very low outside temperatures.

Table 3: Relevant KPIs and related measurement protocols for the heat pump system

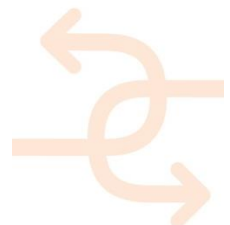

4.2 Real measurements and related devices

The purpose of this section is to provide further details about the measurement variables and protocols required for the calculation and evaluation of the selected KPI's in Table 3. Important aspects such as when (time planning), by whom (executer / responsible staff) and how (details of the measurement procedure, necessary devices, etc.) will be addressed also.

First, it should be noted that the identified measurements can be grouped in different levels according to the subsystem of the global MEP/HVAC facilities or, particularly, of the ventilation system to which they are referred to.

The following levels are defined for the heat pump system:

- The components of the heat pump including: Evaporators, Condensers, Refrigerants, Compressors and Pumps.
- The heat pump as a subsystem consisting of all above mentioned components.
- The heat exchanger (ATES)

Table 4 shows the identified relevant measurements grouped into the previous levels as well as general comments related to the limitations that should be imposed to the application of such measurements.

Measurement level	Limitations
Components of the heat pump system including: <ul style="list-style-type: none"> • Evaporators; • Condensers; • Refrigerants; • Compressors; and • Pumps. 	After mounting the heat pump, the expert team tests these components. The on-site test goes through special protocols delivered by the manufacturer. Therefore, test protocols may differ for different manufacturers. For the test built-in sensor and meters are used; a kind of self-testing. The readings appear, in the control panel of the heat pump. <u>Only certified personnel of the manufacturer may perform this test. For this reason, these tests are outside the scope of the INSITER project and will be shortly described in the following sections.</u>
The heat pump: <ul style="list-style-type: none"> • COP for heating • COP for cooling 	After testing the heat pump components, the heat pump has to be tested as a whole system. During this test, the heat pump should reveal that it can deliver the energy demand (heating or cooling) according to the design considerations. <u>The test is a snapshot as it reflects the performance in a particular point in time having very particular weather and occupancy conditions. The outcome of the test can be a good indication of the performance of the heat pump but it doesn't represent the actual performance during the four seasons.</u> This is only possible using monitoring software during one year.

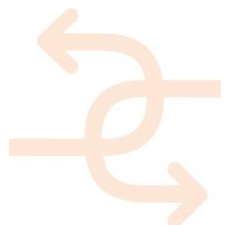

The heat exchanger (ATES)	Testing the ATES is a process that takes one year. During the construction and pre-commissioning it is not possible to measure the SPF. <u>It requires monitoring of the delivered heat/cold and used electricity by the ATES. For this reason performance inspection of the ATES is outside the scope of the INSITER project.</u>
The building level	Total energy consumption of the building is the best indicator of the Energy Efficiency of the building and its related HVAC/MEP systems. <u>However, this process takes one year of monitoring considering four seasons and actual occupancy rates of the building. For this reason performance inspection at the building level is outside the scope of the INSITER project.</u>

Table 4: measurement levels for the heat pump systems

It should be noted that the measurements at this stage of the construction are not representable for the actual measurements in the operation stage. In the most cases not all components/subsystems/systems are installed and inspected and therefore not all inspections/measurements will be executable. Nevertheless, evaluation of these measurements at that stage using diagnosis solutions may give reasonable indication about the real performance. This is how INSITER add value to the current quality control during the construction phase of the project.

4.2.1 General procedure and considerations

Before starting the functional measurements, the following actions need to be taken:

Action	Description
1 Determine the time and planning of measurements	Time and planning is crucial for INSITER's methodology.
2 Link the measurement to an executer	For each measurement, the level of competence and qualities needed to conduct the measurements is specified.
3 Define test conditions and calculations	Functional measurements can take place at other conditions than design conditions. The measurements are allowed to be calculated into design conditions if this is possible. (e.g. possible: heat exchanger efficiency, not possible: seasonal performance factor of an ATES)
4 Select the measurement instrument(s)	For each measurement, one or more instruments are needed. The instruments will be selected based upon their usability on site, the accuracy (or uncertainty) and practical implementation in INSITER methodology. Only calibrated devices shall be used.
5 Define the number of measuring points	For certain measurements, it might be necessary to take multiple measurements at multiple locations. For example to measure the room temperature, depending on the size of the room.

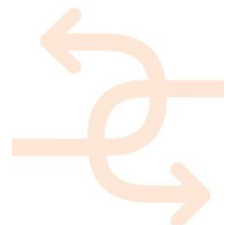

6	Specify the measuring location(s)	The exact locations where the measurements are being carried out will be specified. This is about the location in relation to the HVAC/MEP-system or room and not the general locations in the building.
7	Perform measurement	Describe the actions needed to perform the measurements.
8	Calculations and input of measured values	If applies and if possible, measurements are allowed to be calculated into design conditions or into qualifiable values. Equations are given.
9	Decide on the sequence of inspections and measurements	Measurements may depend on other measurements or are only possible if other components/subsystems are already installed and tested (e.g. air temperature in the room is not only a function of energy delivery by the heating system but also of air flow rates of the ventilation system).

Table 5: Specifications of the measurement protocols: General procedure

4.2.2 Components of the heat pump system

General test

1. Planning: Just after placing the heat pump unit by the mechanical engineering company.
2. Executor: Certified worker (or an expert of the manufacturer).
3. Conditions: The self-inspection has been performed after finishing visual inspection and after completing the first Start-Up and Shutdown test.
4. Instruments: Built-in sensors and meters; self-testing of heat pump.
5. Number: Not applicable.
6. Location: Mounting place of the heat pump.
7. Description: The worker runs the (self) test according to the protocol delivered by the manufacturer.
8. Calculation: No calculation is needed. Readings should correspond to readings prescribed by the manufacturer and consulted by the design specifications. It considers the following values:

Total capacity of the heat pump [%]

Working power between L1/L2 [Voltage]

Working power between L2/L3 [Voltage]

Working power between L3/L1 [Voltage]

Out-of-balance (max 2%) [%]

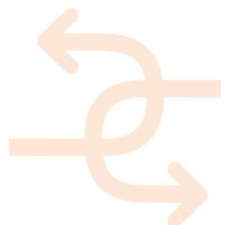

Evaporator

1. Planning: Just after placing the heat pump unit by the mechanical engineering company.
2. Executor: Certified worker (or an expert of the manufacturer).
3. Conditions: The self-inspection has been performed after finishing visual inspection and after completing the first Start-Up and Shutdown test.
4. Instruments: Built-in sensors and meters; self-testing of heat pump.
5. Number: Not applicable.
6. Location: Mounting place of the heat pump.
7. Description: The manufacturer expert runs the (self) test according to the protocol delivered by the manufacturer.
8. Calculation: No calculation is needed. Reading of the evaporator should correspond to readings prescribed by the manufacturer and design specifications. It considers the following values:
Temperature of cooled water (in / out) [°C]
Delta T of cooled water [K]
Cooler approach A | B | C [K]
Frost protection water (temperature) [°C]

Condenser

1. Planning: Just after placing the heat pump unit by the mechanical engineering company.
2. Executor: Certified worker (or an expert of the manufacturer).
3. Conditions: The self-inspection has been performed after finishing visual inspection and after completing the first Start-Up and Shutdown test.
4. Instruments: Built-in sensors and meters; self-testing of heat pump.
5. Number: Not applicable.
6. Location: Mounting place of the heat pump.
7. Description: The manufacturer expert runs the (self) test according to the protocol delivered by the manufacturer.
8. Calculation: No calculation is needed. Reading of the evaporator should correspond to readings prescribed by the manufacturer and design specifications. It considers the following values:
Air temperature in [°C]
Air temperature out [°C]
Measured power @ ventilator 1 [Ampere]
Measured power @ ventilator 2 [Ampere]
Measured power @ ventilator 3 [Ampere]

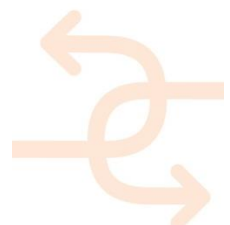

Refrigerant

1. Planning: Just after placing the heat pump unit by the mechanical engineering company.
2. Executor: Certified worker (or an expert of the manufacturer).
3. Conditions: The self-inspection has been performed after finishing visual inspection and after completing the first Start-Up and Shutdown test.
4. Instruments: Built-in sensors and meters; self-testing of heat pump.
5. Number: Not applicable.
6. Location: Mounting place of the heat pump.
7. Description: The manufacturer expert runs the (self) test according to the protocol delivered by the manufacturer.
8. Calculation: No calculation is needed. Reading of the evaporator should correspond to readings prescribed by the manufacturer and design specifications. It considers the following values:
System capacity [%], Ventilator steps [Value], Tour setting [%], Condensation temperature [°C], Pressure [kPa], Liquid temperature [°C], Sub cooling [K], Evaporation temperature [°C], Suction pressure [kPa], Superheating [K], Control EXV [%]

Compressor

1. Planning: Just after placing the heat pump unit by the mechanical engineering company.
2. Executor: Certified worker (or an expert of the manufacturer).
3. Conditions: The self-inspection has be performed after finishing visual inspection and after completing the first Start-Up and Shutdown test.
4. Instruments: Built-in sensors and meters; self-testing of heat pump.
5. Number: Not applicable.
6. Location: Mounting place of the heat pump.
7. Description: The manufacturer expert runs the (self) test according to the protocol delivered by the manufacturer.
8. Calculation: No calculation is needed. Reading of the evaporator should correspond to readings prescribed by the manufacturer and design specifications. It considers the following values:
Measured power [Ampere], Running hours [Value], Running time/start [Minutes]

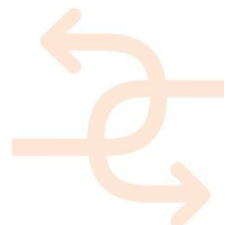

Pumps

1. Planning: Just after placing the heat pump unit by the mechanical engineering company.
2. Executor: Certified worker (or an expert of the manufacturer).
3. Conditions: The self-inspection has be performed after finishing visual inspection and after completing the first Start-Up and Shutdown test.
4. Instruments: Built-in sensors and meters; self-testing of heat pump.
5. Number: Not applicable.
6. Location: Mounting place of the heat pump.
7. Description: The manufacturer expert runs the (self) test according to the protocol delivered by the manufacturer.
8. Calculation: No calculation is needed. Reading of the evaporator should correspond to readings prescribed by the manufacturer and design specifications. It considers the following values:

Measured power [Ampere]

Running hours [Value]

4.2.3 COP of the heat pump

COP for heating

1. Planning: After placing the heat pump unit by the mechanical engineering company and connecting to the distribution circuit/ATES.
2. Executor: Mechanical engineer (can also in collaboration with the commissioning manager).
3. Conditions: The test can be performed by creating energy demand (heat or cold) in part or in the whole building. Heat/cold demand can be created in two ways: using coolers/heaters in the rooms or changing the setpoint in the room. It is preferable to create different levels of demand e.g. full load or part load to examine how the heat pump will perform at different load levels (different conditions).
4. Instruments: Resistance thermometers are used to measure the temperature of the transport fluid (inlet flow and outlet flow). Flow meters to measure the amount of transport fluid. And power meter (watt-meter) to measure the electricity power consumed by the heat pump. However, the most heat pump units have all this meters built-in and readings can be found on the display panel of the unit.
5. Number: At least full load, part load and minimum load.
6. Location: Mounting place of the heat pump.
7. Description: The mechanical engineer (in some cases together with a commissioning manager) runs the test.
8. Calculation: $COP = \text{heat or cold produced by the heat pump (kWh, J, Btu/h)} \div \text{the equivalent electric energy consumed by the heat pum (Btu/h, J, kWh)}$.

The evaluation of the COP calculations will be further discussed in Section 4.4 based on the new dignosis approach (simulation based self-inspection).

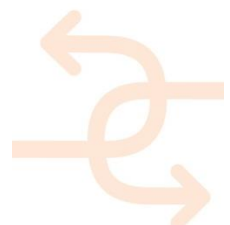

4.2.4 Test report on the measurements

For all measurement procedures, the report of the results shall contain the following information:

- Set points and permitted tolerances;
- Operating conditions such as load, control settings and weather conditions (if they influence the measurement results);
- Measuring locations and measuring points and drawings if necessary;
- Used measuring instruments and procedure;
- The measured values including date and time;
- Evaluation of the measurements (within or outside the permitted tolerances).

A copy of test report of the heat pump has to be included to the heat pump dossier and be stored close to the heat pump.

4.3 Identification of difficulties

Based on the previous sections, the inspection of a list of measurements is proposed to help the worker identify critical problems during the installation phase that might reduce systems' performance in the following stages of the building life causing delays, more intensive maintenance and/or increasing operating costs. Measurements need to be practical and simple, therefore, a few aspects, related to measurements of heat pump systems, need attention:

- **Schedule** is a key challenge of the inspection measurements. Heat pump systems, including all subsystems and components, have to be operational to evaluate the actual performance. The biggest challenge is to properly schedule all inspection measurements considering how components and subsystems depend on each other and may affect performances of each other.
- In which **conditions**, onsite or outside the building, measurements are conducted is very crucial for the final evaluation of delivered performance. Weather conditions, temperature of ATES water can lead to distorted results. Best performance evaluation of heat pump system can only be drawn after, at least, one year of operation considering four different seasons. However, the presented INSITER approach provides a good indication for performance to be delivered.
- The INSITER approach transfers essential inspection measurements to the workers themselves. However, in practice, **responsibilities** related to inspection and quality issues are located to other actors including site supervisor or commissioning authorities. For this reason, superfluous self-inspection measurements have to be avoided during design the INSITER approach. The focus was supporting workers to avoid mistakes in a simple way without burdening the running process.
- Every measurement can be a subject to **uncertainties** that may arise from the layout and method of measurement, the measuring equipment, and from taking the reading. Uncertainties may be caused by the measurement conditions as discussed above but also due to uncertainties of the measuring devices (especially built-in meters and sensors). It is recommended, if possible, to use external well-calibrated meters and measuring devices.

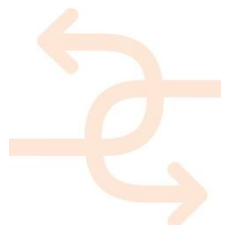

4.3.1 Limitations

Next to the difficulties, there are also some limitations to the self-inspection process of the heat pump system:

- The performance of the whole heat pump cannot be measured since there is no actual thermal load from the building. The future appliances and occupants obviously have a great effect on the internal heating load and therefore the performance of the heat pump system. The measurement results therefore are **limited** to the performance considering partial thermal load and will only expose possible errors that influence critical performance. INSITER methodology acknowledges this limitation.
- As discussed earlier, heat pump systems are complex to be inspected as they figure as a **black box**. Although if all components of the heat pump perform properly, it is imaginable that measurements show lower COP value. This is because of measurement conditions and the large number of factors influencing the delivered heat/cold (e.g. water pressure and temperature). In that case, detailed inspections should be done by specialized workers should be conducted to clarify possible performance deviations.
- Performance of the heat pump system may be affected by the performance of **other HVAC/MEP systems or by the quality of the building envelope**. Deviations in performance are hard to correctly be estimated and allocated to right cause/origin. Long term monitoring at the component level is essential in this case.
- The selected measurements, like stated before, do not fully cover all the necessary heat pump tests, but **focus on the critical performance** and quality indicators, as defined in D1.6.
- Measurements have to be carried out by skilled workers. However, experience and knowledge levels are subject to regional legislations and possible practical restrictions.

4.4 Diagnosis and related KPI's

The purpose of this section is to define a procedure to diagnose the impact of measured deviations on the real performance of the heat pump system. Because of the mentioned limitations of the inspection stage, measurements taken on instant or relatively short tests are not directly representative for the real performance of the entire system. In the sections above, we agreed that COP of the heat pump is an important measurement for the performance of the system. To understand the impact of a accidentally deviation of the COP-heating of the heat pump, a sensitivity analyse has been done using simulation software for a real building². Figure 25 illustrates the new diagnosis approach for the heat pump.

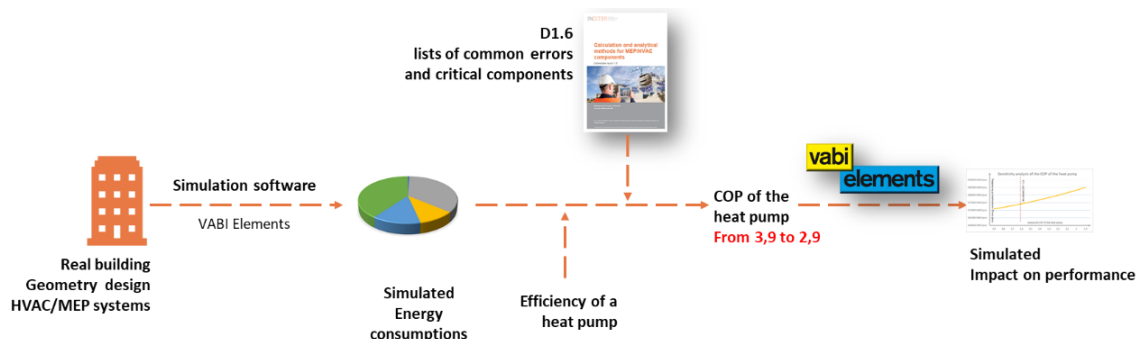
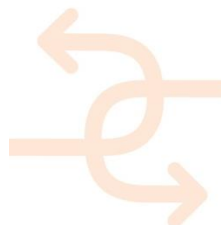

Figure 25: the new diagnosis approach for the heat pump

² For this purpose we simulated a building from the portfolio of DWA because of the completeness of the simulation input (geometrical and HVAC/MEP design and also because of the way the building is structured (design at the room level). Unfortunately, no building of the demo sites suits the requirements of the VABI elements input.



The designed COP-heating of the heat pump is 3.9. Performance deviations from COP=3.9 to COP=2.9 have been re-simulated using the simulation software. For every step, the total energy consumption of the whole building have been noted. The final output of the deviation simulations is a graph presenting the relationship between the measured COP of the heat pump and its impact on total energy consumption of the building (Energy Efficiency). See Figure 26. This graph, created in the design stage, will be used by the workers to support them performing the self-inspection activities and taking validated evaluation decisions.

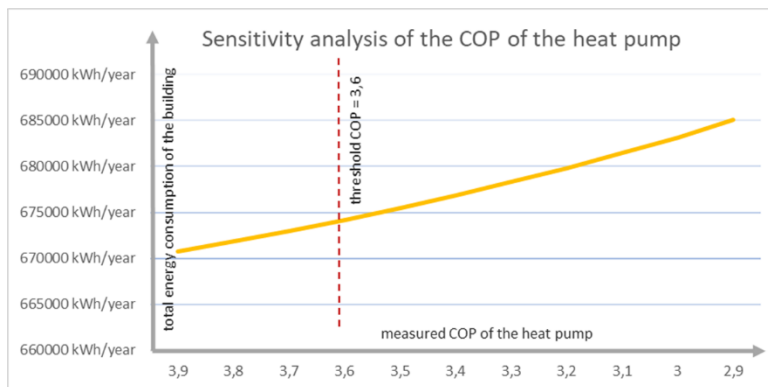
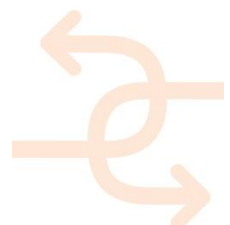

Figure 26: the relationship between the measured COP and its impact on the total energy consumption

4.5 Thresholds and tolerances

The following thresholds and tolerances are defined in order to avoid unacceptable deviations on the performance of the heat pump system, as derived from INSITER measurement results and as prescribed by the manufacturers.

A desired value (DV) is chosen as the ideal outcome to be obtained from each measured KPI, generally the design value. In addition, a tolerance range allows for uncertainty and limitations on the inspection tests, so, if the measurement result is within this tolerance range, the installation should be accepted. Otherwise, the installation should be rejected and additional measures would need to be taken to correct the detected faults.



KPI	Unit	Desired Value (DV)	Tolerance	Remarks
COP of the heat pump	Value	Design	5%	As discussed above, other tolerance values may be agreed by the building designers, commissioning authorities and building owners based on the simulated impact of deviations on deviated performance measurement.
Heat pump general Total capacity of the heat pump Working power between L1/L2 Out-of-balance	% Voltage Voltage Voltage %	Design and based on selected heat pump	Prescribed values by the manufacturer	For these measurements recommended prescribed values by the manufacturer are decisive.
Evaporators Temperature of cooled water Delta T of cooled water Cooler approach A B C Frost protection water temp.	[oC] [K] [K] [oC]	Design and based on selected heat pump	Prescribed values by the manufacturer	For these measurements recommended prescribed values by the manufacturer are decisive.
Condensers Air temperature in/out Measured power @ ventilator	[oC] [Ampere]	Design and based on selected heat pump	Prescribed values by the manufacturer	For these measurements recommended prescribed values by the manufacturer are decisive.
Refrigerants System capacity Ventilator steps Tour setting Condensation temperature Pressure Liquid temperature Sub cooling Evaporation temperature Suction pressure Superheating Control EXV	[%] [Value] [%] [oC] [kPa] [C] [K] [o] [ka] [K] [%]	Design and based on selected heat pump	Prescribed values by the manufacturer	For these measurements recommended prescribed values by the manufacturer are decisive.
Compressors Measured power Running hours Running time/start	[Ampere] [Value] [Minutes]	Design and based on selected heat pump	Prescribed values by the manufacturer	For these measurements recommended prescribed values by the manufacturer are decisive.
Pumps Measured power Running hours	[Ampere] [Value]	Design and based on selected heat pump	Prescribed values by the manufacturer	For these measurements recommended prescribed values by the manufacturer are decisive.

Table 6 : Thresholds and tolerances for the heat pump system

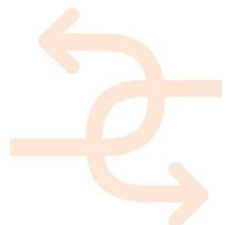

5. Ventilation system

From the construction point-of-view, the ventilation system consists of a large amount of components that need to be mounted and connected. The guidelines describe the INSITER methodology that reduces building errors by enabling self-inspection on the construction site. Once the entire system is installed and operable, the performance of the entire system depends on how well components are adjusted and working together. To evaluate this performance, several subsystems need to be inspected by measuring related performance indicators (PIs).

Generally, a ventilation system consists of the following subsystems (see Figure 27):

- A ventilator (or air handling) section [green],
- A distribution section [grey],
- A terminal section [blue], and
- A control system.

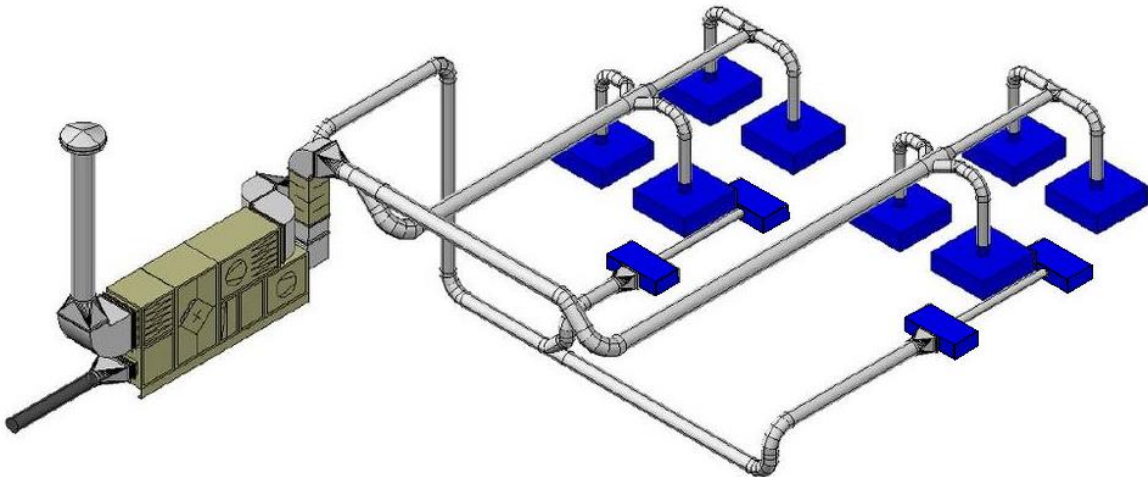
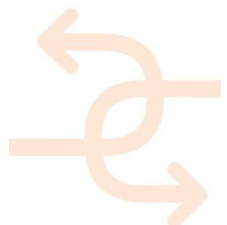

Figure 27: 3D Scheme of a ventilation system [source 14]

All these subsystems are individually measurable on different aspects. For example, the distribution section that consists of the ducts and several in-duct components can be measured and evaluated on the air tightness of this particular section. If inconsistencies are identified, the section does not meet its desired performance and might have to be adjusted or repaired.

In this chapter, a simplified method for measurement and diagnosis is described that contributed to reduction of performance and quality for ventilation systems. The method is general in a sense, so that for every building project the actions would be practically the same.



5.1 Measurement protocols and related variables

The purpose of the functional measurements is to give proper assurance that the system achieves the design conditions and set points as specified. In INSITER we defined a set of KPIs related to the energy efficiency (EE) and indoor environmental quality (IEQ). Each of these KPIs will be validated by measuring the relevant values, in order to be able to evaluate the quality of the delivered work.

Thought all measurements could reduce the amount of errors significantly, it is not possible to cover all possible mistakes by measurement. And also, not all measurements will contribute subsequently to the effort put into it. For example, thermographic photography can contribute to better insulation of the ducts, but the effort to do so, does not outweigh the possible results. The temperature difference between inside and outside of the ducts is not very high and a visual inspection of gaps is therefore more efficient.

For the ventilation system, the table below shows the relevant KPIs and desired measurement protocol to evaluate the performance.

KPI	Measurement protocol	Description and goal
Efficiency of heat transfer (EE)	Efficiency of heat exchanger	The efficiency of a heat exchanger or a heat recovery element contributes to the overall energy performance of the ventilation system. Basically, there's no indication that the heat exchanger performs lesser than design specifications. So this measurement will only be conducted in case there is reason to do so (e.g. following results from other measurements)
	Ductwork leakage	During self-inspection, the MEP worker checks the connection of the duct sections. When the entire duct system is finished, it is important to check whether the duct system is airtight. If it's not, heat loss will derive from it. The ductwork leakage measurement verifies this airtightness.
Efficiency of electrical components (EE)	Electrical power of the fan	The electricity use of the fan depends on the nominal power of its motor drive. In turn, the power depends on the pressure drop of the entire ventilation system and the total air flow displacement of the fan. High pressure drops lead to higher electricity consumption and must be avoided.
	Pressure difference across air filter	The pressure difference across the air filter is an indication for the pollution of the filter, but also for leakages alongside filters and frame. Although this can influence the efficiency of heat transfer, the pressure increase due to pollution has a greater effect on the efficiency of the ventilation system. Because of the higher pressure difference, the electricity use of the fan and motor increases.

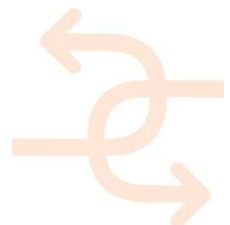

KPI	Measurement protocol	Description and goal
Thermal Comfort (IEQ)	Indoor air velocity	If the mounting of air terminal devices, like diffusers, diverges from the (to be concerned: flawless) design, it might occur that air velocities exceed the threshold values. High air velocities can lead to discomfort and therefore it is necessary to check if the realized ventilation system meets the design specifications.
	Air temperature	The air temperature in the room depends on the right installation and right setting of the heating and ventilation system (if heat is transferred by the air handling unit). Measuring the air temperature verifies correct installation and operation of the ventilation system.
	Air humidity	The humidity in the room depends on the right installation and right setting of the ventilation system (if a (de)humidifier is integrated in the air handling unit). Measuring the air humidity verifies correct installation and operation of the ventilation system.
Acoustic Comfort (IEQ)	Sound pressure level	Sound or noise transferred by the ventilation system can cause major discomfort. It depends for a great deal on a correct design, but is also depending on correct installation and setting of components in the ventilation system. Measuring the sound pressure level in the room contributes to the verification that the installation and operation of the ventilation system is correct.
Indoor Air Quality (IEQ)	Air flow rates	Lack of suitable air flow rates can be caused by multiple errors, e.g. wrong filters, air leakage, wrong balancing, incorrect connection of components, and more. The air flow rates are important to guarantee a good indoor air quality. Air flow rates will be measured at different locations in- and outside of the ventilation system.
	CO ₂ -level	A healthy CO ₂ -level in the room depends on two main factors: CO ₂ -emission and sufficient fresh air. The latter is measured as the air flow rate in a room. And since the first one can only be measured when the room is occupied, it is out of scope for INSITER tools.

Table 7: Relevant KPIs and related measurement protocols for the ventilation system



5.2 Real measurements and related devices

The purpose of this section is to provide further details about the measurement variables and protocols required for the calculation and evaluation of the selected KPIs. Important aspects such as when (time planning), by whom (executer / responsible staff) and how (details of the measurement procedure, necessary devices, etc.) will be addressed next.

First, it should be noted that the identified measurements can be grouped in different levels according to the subsystem of the global MEP/HVAC facilities or, particularly, of the ventilation system to which they are referred to.

The following levels are defined for the ventilation system:

- Entire system: consisting of all subsystems and components.
- Central system or appliance: this is the air handling or ventilation unit, where the fan that takes care of air displacement.
- Ductwork: the distribution section, including all components that are embedded in the duct system.
- Room: this level includes the air terminal devices (ATDs) that deliver the conditioned air into the room.

Table 8 shows the identified relevant measurements grouped into the previous levels as well as general comments related to the limitations that should be imposed to the application of such measurements.

Measurement level	Limitations
Entire system: • Additional cleanliness test;	
Central system or appliance: • Power of the fan (motor); • Efficiency of heat exchanger; • Air flow rates; • Pressure difference across filter;	(in case of heat recovery and only if necessary) (for supply and return air)
Ductwork; • Ductwork leakage;	
Room: • Air flow rates; • Air temperature; • Air humidity; • Sound pressure level; • Indoor air velocity.	(for supply and return air) (in case of heating and/or cooling) (in case of cooling and/or humidifying) (in case of heating, cooling and/or humidifying)

Table 8: Measurement levels for the ventilation system

It should be noted that the measurements on room level are carried out before building delivery, and therefore are not representable for the values once the building is occupied. This is important, and one should understand that the measurement results are evaluated against the technical performance of the ventilation system and NOT the operational performance. For example, the air humidity may be sufficient at the time measurements are carried out. But the humidification may lack performance while the building is occupied due to different conditions.

Nevertheless, evaluations of these measurements on the technical performance do contribute to the added value of INSITER and may resolve some errors.



5.2.1 General procedure and considerations

Before starting the functional measurements, the following actions need to be taken:

Action	Description
1 Determine the time and planning of measurements	Time and planning is crucial for INSITER’s methodology.
2 Correlate the measurement to an executer	For each measurement, the level of competence and qualities needed to conduct the measurements is specified.
3 Define test conditions and calculations	Functional measurements can take place at other conditions than design conditions. The measurements are allowed to be calculated into design conditions if this is possible. (e.g. possible: heat exchanger efficiency, not possible: air flow pattern in a room)
4 Select the measurement instrument(s)	For each measurement, one or more instruments are needed. The instruments will be selected based upon their usability on site, the accuracy (or uncertainty) and practical implementation in INSITER methodology. Only calibrated devices shall be used.
5 Define the number of measuring points	For certain measurements, it might be necessary to take multiple measurements at multiple locations. For example to measure the room temperature, depending on the size of the room.
6 Specify the measuring location(s)	The exact locations where the measurements are being carried out will be specified. This is about the location in relation to the HVAC/MEP-system or room and not the general locations in the building.
7 Perform measurement	Describe the actions needed to perform the measurements.
8 Calculations and input of measured values	If applies and if possible, measurements are allowed to be calculated into design conditions or into qualifiable values. Equations are given.

Table 9: Specifications of the measurement protocols: General procedure

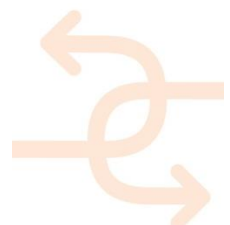

5.2.2 Entire system measurements

Additional cleanliness test

1. Planning: The additional (and final) cleanliness test will be conducted when the building is free of dust and other pollution.
2. Executor: The executor must have knowledge about dust quantity rating and about the importance of a clean ventilation system. Taking these measurements require logical-thinking and basic technician skills. He or she must be competent to independently put the knowledge into practice.
3. Conditions: The cleanliness test must be conducted with the ventilation system switched off. Details that may affect the air quality must be noted.
4. Instruments: The dust quantity within components (like ducts) can be measured using dust tape, in accordance with the recommendations of ISO 8502-3.
5. Number: The number of measurements equals $Q/5000$, where Q is the total air flow rate in that part of the building or ventilation system (air supply and return separately).
6. Location: Any part of the ventilation system where pollution may be expected. The location where the samples are taken must be registered in the test report.
7. Description: The installation must be kept as clean as possible during the realization phase and must be clean and dust free at building delivery. The cleanliness must be measured in particles per area, which is measurable by dust quantity rating. Of the measurement in a duct section or component, a photo is taken in order to define place and location. The dust quantity is expressed as percentage of dust covering the surface.
8. Calculation: No calculation is needed.

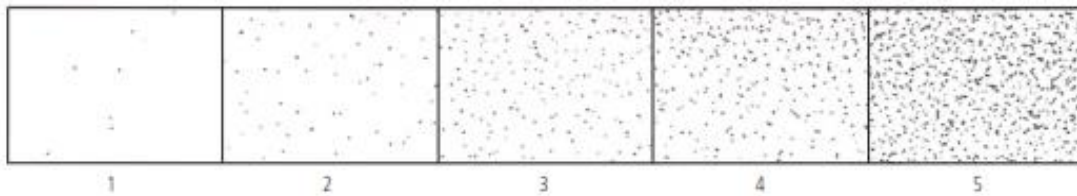
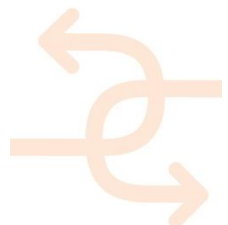

Figure 28 : Pictorial references corresponding to dust quantity ratings 1, 2, 3, 4 and 5.



5.2.3 Central system or appliance measurements

Power of the fan (motor)

1. Planning: The power of the fan can be measured during commissioning of the ventilation or air handling unit.
2. Executor: The executor must have electrical skills and know about safety measures concerning electrical installations. Taking measurements require logical-thinking skills, math skills and basic technical skills. In some cases national certificates may apply.
3. Condition: The electrical characteristics shall be measured at the ventilation system design air flow rate. The control system is set to maintain steady conditions during the measurement. Before measuring the setting of the motor safety cut-out should be checked
4. Instruments: The electrical power consumed is measured either directly by a power meter (watt-meter) or indirectly from the electrical work (kWh-meter) performed by taking the electric meter readings before and after the test. For measuring the power instrument transformers, power meters and electricity consumption meters of an accuracy up to $\pm 1,0$ W shall be used.
5. Number: The number of measurements equals the number of fans and motors in the ventilation system.
6. Location: The measuring equipment should be connected as near as possible to the connection terminals of the individual system components. The layout of the measuring equipment and cables should be such that no errors due to interference from magnetic fields can occur. The cables should be of sufficient rating that an error is not introduced into the measured result.
7. Description: The wattmeter is an instrument that uses voltage and current to determine power in watts. For a single-phase two-wire circuit, one wattmeter with one voltage and one current measurement is sufficient. For three-phase motors, two watt-meters are needed.
8. Calculation: Watt-meter 1 gives electrical power P_1 with:

$$P_1 = U \cdot I \cdot \cos(-30^\circ + \varphi)$$

Watt-meter 2 gives electrical power P_2 with:

$$P_2 = U \cdot I \cdot \cos(30^\circ + \varphi)$$

The total electrical power P_e is given by P_1+P_2 .

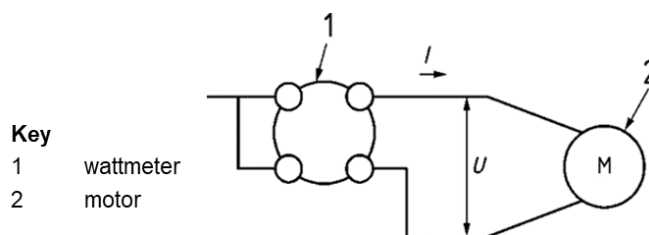
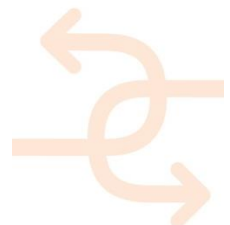

Figure 29 : Measurement of power for an AC single-phase motor [source 4]



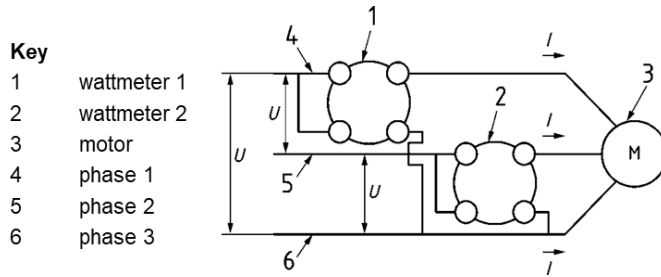
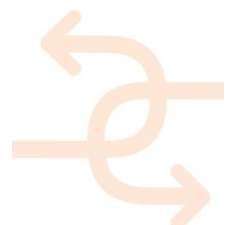

Figure 30 : Measurement of power for an AC three-phase motor [source 4]

Efficiency of heat exchanger

1. Planning: The efficiency of a heat (recovery) exchanger is only measured if present and after other measurements (i.e. temperature and humidity in the room) are conducted.
2. Executor: The executor must have knowledge about heat (recovery) exchangers and their purpose. Taking the measurements require logical-thinking and basic math and technician skills. He or she must be competent to independently put the knowledge into practice.
3. Condition: Operating conditions such as load, control settings and weather conditions which can influence the measurement results must be noted. The minimum temperature difference over the heat exchanger must be at least 50% of the design values. The efficiency of the heat exchanger shall be measured at the ventilation system design air flow rate.
4. Instruments: Resistance thermometers are used to measure the air temperature. For moisture content, at the outlet and inlet of the heat exchanger.
5. Number: All measurements necessary to calculate the efficiency of the heat exchanger.
6. Location: At the inlet and outlet of the heat exchanger. Heat recovery exchangers have 4 sides: at the inlet there's the (1) outdoor air and (2) return air on the building side. On the outlet side there's an (3) exhaust air and (4) supply air on the building side.
7. Description: The temperature ratio value of the heat exchanger (the difference between the temperature of the heated air stream before and after the heat exchanger divided by the maximum temperature difference over the heat exchanger) and the temperature of supply air. The air flow and air temperature at inlet and outlet of the heat exchanger shall be measured. In the case of heat recovery systems with humidity transmission, the moisture content at inlet and outlet shall be measured.



8. Calculation: The efficiency is defined as the temperature ratio value of the heat exchanger (the difference between the temperature of the heated air stream before and after the heat exchanger divided by the maximum temperature difference over the heat exchanger) and the temperature of supply air. Calculation of the actual efficiency is by using this equation:

$$\eta_t = \frac{(\theta_{p,out} - \theta_{p,in})}{(\theta_{s,in} - \theta_{p,in})}$$

Where,

- η_t is the temperature transfer efficiency of the heat exchanger;
- $\theta_{p,in}$ is the temperature of primary air before the heat exchanger in °C;
- $\theta_{p,out}$ is the temperature of primary air after the heat exchanger in °C;
- $\theta_{s,in}$ is the temperature of secondary air before the heat exchanger in °C.

The latent transfer efficiency of a heat recovery unit can be expressed as:

$$\eta_x = \frac{(x_{p,out} - x_{p,in})}{(x_{s,in} - x_{p,in})}$$

Where,

- η_x is the latent transfer efficiency of the heat exchanger;
- $x_{p,in}$ is the moisture content of primary air before the heat exchanger in kg/kg;
- $x_{p,out}$ is the moisture content of primary air after the heat exchanger in kg/kg;
- $x_{s,in}$ is the moisture content of secondary air before the heat exchanger in kg/kg.

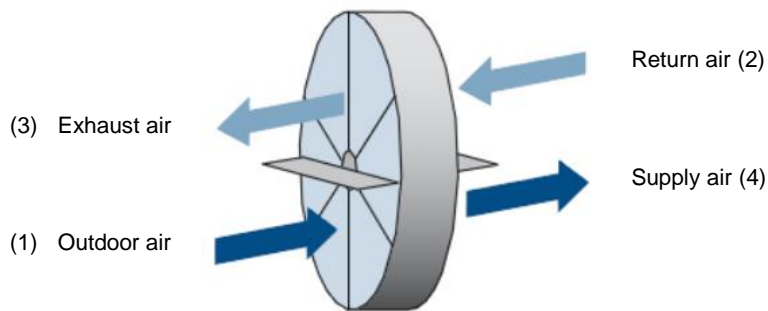
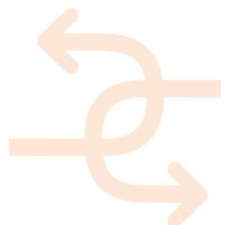

Figure 30 : Heat recovery unit with a rotating wheel



Air flow rates

1. Planning: The airflow rates in the room are measured for supply and return air. The measurement will be conducted after balancing the ventilation system and before hand over of the building.
2. Executor: Taking measurements require logical-thinking skills, math skills and basic technical skills. In some cases national certificates may apply.
3. Condition: Operating conditions such as load, control settings and weather conditions which can influence the measurement results must be noted. The air flow control systems is set to meet the design specifications.
4. Instruments: The air velocity in a duct cross-section is measured by a Pitot or Pitot Static tubes (Prandtl tube) with thermo-anemometer and the airflow is calculated from the measured value(s).
5. Number: The air flow rates of the supply and return air are measured.
6. Location: Air velocity measurements will be conducted at a place where the air velocity is evenly distributed over the duct. So measurements close after a bend, narrowings or devices, must be avoided.
7. Description: In case of rectangular duct, the duct cross-section needs to be divided in rectangles with equal areas. For circular ducts, the cross-section is divided into circular sections. In each area or section, a measurement is taken. The air velocity is calculated out of all measurements at the cross-section. Subsequently, the air flow is calculated by the equation mentioned below. The measured air flow must correspond to the design air flows as described in the procedure.
8. Calculation: To calculate the air flow at the duct cross-section, the following equation is needed:

$$q_v = A \cdot v_a \cdot 3600 \text{ in } [m^3/h]$$

Pressure difference across filter

1. Planning: The pressure difference across a filter section can be measured during commissioning of the ventilation or air handling unit.
2. Executor: Taking measurements require logical-thinking skills, math skills and basic technical skills. In some cases national certificates may apply.
3. Condition: Use clean (new) filters. The pressure difference shall be measured at the ventilation system design air flow rate. A constant volume flow is provided by blocking control(s).
4. Instruments: The pressure difference shall be measured by means of suitable (micro-)manometers. Manometers incorporated at the filters are sufficient for the functional measurement of the pressure difference.
5. Number: The number of measurements equals the number of filter sections in the ventilation system.
6. Location: The measuring equipment is generally connected to the air handling unit. The measuring nipples must be placed at the air inlet and air outlet of the filter.
7. Description: The micromanometer reads 0 Pa (Pascal) when the system is out of operation. Connected to the meter are two air hoses, each of the hoses leading to the measuring nipples on either side of the filter section.
8. Calculation: No calculation required.



5.2.4 Ductwork measurements

Ductwork leakage

1. **Planning:** The leakage measurement shall be performed while the duct is being installed and accessible. After start of operation a second tightness test can be necessary, only if an irregularity happens during the start up. This, however, is not part of INSITER.
2. **Executor:** Taking measurements require logical-thinking skills, math skills and basic technical skills. In some cases national certificates may apply.
3. **Condition:** The pressure difference shall be measured at the ventilation system design air flow rate. A constant volume flow is provided by blocking control(s).
4. **Instruments:** For pressure measurement in a duct cross-section, a pitot tube with micromanometer is used. The micromanometer must be calibrated and can measure in a range from 0 Pa to 2000 Pa. The required accuracy of the measuring device is $\pm \frac{0,02 \text{ mm}}{\text{reading value in mm}} \times 100 \text{ in } \%$.

For air flow measurement, see section about air flow rates.
5. **Number:** The number of measurements follows the number of duct sections to be installed.
6. **Location:** Measurement is taken at the beginning and at the end of each section.
7. **Description:** The leakage of the ductwork is important for the energy efficiency of the complete air conditioning system. The tightness class according to EN 1507 and EN 12237 shall be checked.

The duct section on which a pressure test is carried out is marked on the drawing. As soon as the section has been completely installed, all openings are sealed off. A fan which is connected to the sealed duct system through equipment for measuring is used to generate a test pressure difference above or below atmospheric pressure. The test pressure should be adjusted to one of the following values which should be chosen to be as near as possible to mean operating pressure of the system, preferably:
 - 200 Pa, 400 Pa, or 1000 Pa above atmospheric in case of supply air ducts, or
 - 200 Pa, 400 Pa or 750 Pa below atmospheric in case of exhaust air ducts.
 The pitot tube is placed in the air flow. One must wait for long enough during the measurement until the value is stable. The static pressure P_s is displayed in Pa (Pascal) or N/m^2 .
8. **Calculation:** The mean operating pressure is the arithmetic mean of the static pressure at the beginning and end of a section of air ducting.

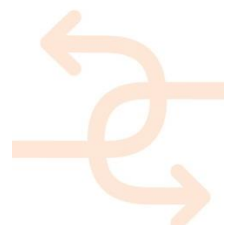

5.2.5 Room measurements

Air flow rates

1. **Planning:** The airflow rates in the room are measured for supply and return air. The measurement will be conducted after balancing the ventilation system and before hand over of the building.
2. **Executor:** Taking measurements require logical-thinking skills, math skills and basic technical skills. In some cases national certificates may apply.
3. **Condition:** Before measurement, the control settings are recorded. All air flow control systems need to be blocked while taking measurement.
4. **Instruments:** The air velocity in a duct cross-section is measured by a Pitot or Pitot Static tubes (Prandtl tube) with thermo-anemometer and the airflow is calculated from the measured value(s). Alternatively, the air flow can be measured at the air terminal devices (ATDs) in the room, by use of a measuring funnel (Capture Hood). Because of the uncertainty of this method, the measurements need to be checked with the duct cross-section method.
5. **Number:** A measurement is taken at each ATD, so the number of measurements equals the total amount of ATDs.
6. **Location:** The duct cross-section measurements will be conducted at a place where the air velocity is evenly distributed over the duct. So measurements close after a bend, narrowings or devices, must be avoided.
Measuring positions for funnel measurement is at the outlet of the ATDs.
7. **Description:** For the duct cross-section method: In case of rectangular duct, the duct cross-section needs to be divided in rectangles with equal areas. For circular ducts, the cross-section is divided into circular sections. In each area or section, a measurement is taken. The air velocity is calculated out of all measurements at the cross-section. Subsequently, the air flow is calculated by the equation mentioned below.
For the funnel measurement method, it is needed to check how much the meter deviates. To do this, make an air flow measurement as mentioned above in the final duct section to one of the ATDs. Then, carry out the funnel measurement by placing the funnel over the ATD. The fraction difference is used to compensate all measurements.
8. **Calculation:** To calculate the air flow at the duct cross-section, the following equation is needed:

$$q_v = A \cdot v_a \cdot 3600 \text{ in } [m^3/h]$$

From the funnel measurements, the supply air flow in the room is the sum of all supply airflows from the ATDs. The return air flow in the room is the sum of all return airflows from the ATDs.

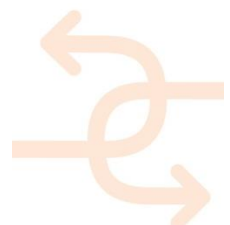

Air temperature

1. Planning: The indoor air temperature measurement is only performed in case the ventilated air is heated and/or cooled. The measurement will be conducted after balancing the ventilation system and before hand over of the building.
2. Executor: Taking measurements require logical-thinking skills, math skills and basic technical skills. In some cases national certificates may apply.
3. Condition: The outdoor temperature and humidity is measured. The air temperature is measured at the ventilation system design air flow rate. The climate-control system for the room needs to be blocked, to maintain steady conditions during the measurement.
4. Instruments: Measurement of the temperature in a room is done with a resistance thermometer. The thermometer must be calibrated and can measure in a range from 10 °C to 40 °C. The required accuracy of the measuring device is $\pm 0,5$ °C.
5. Number: At least one measuring position is required for measurements in rooms of area up to 20 m² ; larger rooms should be subdivided accordingly. To cover a sufficient amount of measurements and determine their location, the recommendations of the Dutch Building Commissioning Association (DBCxA) can be followed (see tables below).
6. Location: The temperature measurement should be done at the correct height (ankle height, chest height and head height of occupants) and take into account the circumstances like radiation from walls and ceiling, radiant panels, radiators and the sun. Also avoid influence from heat emission of people and equipment. The measurement can take place centrally in the room or, if identifiable, at positions intended for intensive occupancy. See also the recommendations of the DBCxA in the tables below.
7. Description: The thermometer is put into the right place and turned on. It takes time for the meter to acclimatise to the room temperature. This certainly applies if the meter was outside at a cold outside temperature. As soon as the meter reaches equilibrium, the meter indicates a constant value.
8. Calculation: No calculation required.

Room dimension [A in m ²]	Number of measurements	Locations [see Table 11]
A ≤ 10	1	1
10 < A ≤ 50	2	2, 3
50 < A ≤ 300	3	1, 2, 3
A > 300	5	1, 4, 5, 6, 7,

Table 10: Number of measurements [source 6]

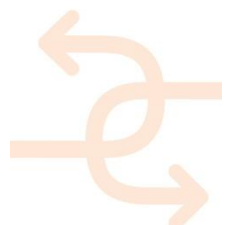
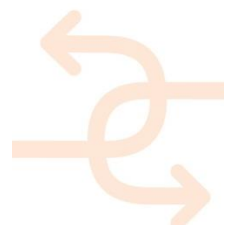



Table 11: Location of measurements [source 6]

Air humidity

1. **Planning:** The indoor air humidity is only measured in case the ventilated air is (de-)humidified. The measurement will be conducted after balancing the ventilation system and before hand over of the building.
2. **Executor:** Taking measurements require logical-thinking skills, math skills and basic technical skills. In some cases national certificates may apply.
3. **Condition:** The outdoor temperature and humidity is measured, and also the indoor air temperature. Note that the relative humidity depends on the air temperature. The air humidity is measured at the ventilation system design air flow rate. The climate-control system for the room needs to be blocked, to maintain steady conditions during the measurement.
4. **Instruments:** The use of recording instruments is necessary. Preferably, a psychrometer or thermo-hygrometers is used, in combination with a logger. The meter must be calibrated and can measure in a temperature range from 10 °C to 40 °C, measuring the relative humidity between 0 and 100%. The required accuracy of the measuring device is $\pm 2\%$.
5. **Number:** At least one measuring position is required for measurements in rooms of area up to 20 m² ; larger rooms should be subdivided accordingly.
6. **Location:** The humidity measurement should be conducted centrally in the room, or if identifiable, at positions intended for intensive occupancy. Although the amount of moisture in a room is fairly homogeneous, the relative humidity can differ per measurement. This is caused by the layering of the temperature in a room. Therefore, it is important that the temperature measurement is conducted at the same position. Locations where the equipment is subject to exposure to radiation from climate ceilings, radiant panels, radiators and the like, must be avoided. Also to avoid influence from heat emission of people and equipment and direct radiation from the sun.
7. **Description:** The hygrometer and logger are put into the right place and turned on. It takes time for the meter to acclimatise to the room temperature, approximately 5 minutes. When acclimatised, start the logging function and log for at least 24 hours.
8. **Calculation:** No calculation required.



Sound pressure level

1. **Planning:** The sound pressure level measurement will be conducted after balancing the ventilation system and before hand over of the building.
2. **Executor:** Taking measurements require logical-thinking skills, math skills and basic technical skills. In some cases national certificates may apply.
3. **Condition:** Purpose is to measure the sound pressure level caused by the ventilation system. Because the influence of other sounds must be excluded, in all cases the background sound pressure level shall additionally be recorded, when the system is not in operation. The reverberation time in the room is not measured; however, the noise level in the furnished situation will be lower than is measured in the empty room.

The sound pressure level is measured at the ventilation system design air flow rate. The climate-control system for the room needs to be blocked, to maintain steady conditions during the measurement.
4. **Instruments:** A sound level meter is used. The required accuracy of the meter is $\pm 0,5$ dB and the meter must be calibrated.
5. **Number:** Three dB(A) measurements are taken, spread out over the room. All measured values must not exceed the threshold.
6. **Location:** The measuring points are to be selected at a sufficient distance from the diffusers and ducts ($\geq 1,0$ meter) and at a sufficient distance from other objects and people ($\geq 0,5$ meters).
7. **Description:** Windows, interior doors and exterior doors need to be closed and all interference noises must be disabled. At the beginning of a series of measurements, the operation of the sound meter must be checked with the help of a calibration sound source. The time-averaged sound pressure level is measured over a period of at least 8 seconds.
8. **Calculation:** No calculation required.

Indoor air velocity

1. **Planning:** The measurement of indoor air velocity in the room is only measured in case the ventilated air is heated, cooled and/or humidified. The measurement will be conducted after balancing the ventilation system and before hand over of the building.
2. **Executor:** Taking measurements require logical-thinking skills, math skills and basic technical skills. In some cases national certificates may apply.
3. **Condition:** The air temperature in the room is measured and should be 20 °C. The indoor air velocity shall be measured at the ventilation system design air flow rate. The climate-control system for the room needs to be blocked, to maintain steady conditions during the measurement.

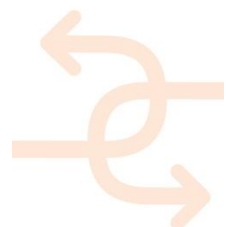

4. Instruments: The indoor air velocity should preferably be determined by means of an omnidirectional probe which is sensitive to the velocity from whatever direction. The measuring equipment must be sufficiently suitable to accurately measure low air velocities, from 0,05 m/s to 1,0 m/s. The required accuracy of the measuring device is $(0,05 + 0,05 \cdot v_a)$ m/s.



Figure 31 : Omnidirectional probe for indoor air velocity measurement

The accuracy of the results of measurement of room air flow using the measurement methods described depends mainly on the differing properties of the measurement probes and on the systematic error of the measuring equipment. Therefore, the probes have to meet the minimum requirements and be regularly calibrated.

5. Number: At least one measuring position is required for measurements in rooms of area up to 20 m² ; larger rooms should be subdivided accordingly.
6. Location: Indoor air flow is usually a turbulent flow. The air velocity varies from place to place within the room, the variations being random with regard to magnitude and direction. Attention should be given to the location in relation to the windows, sun shade blinds, walls, floor, ceiling and possible air leakages, heat sources (lighting, machines), type and location of furniture and the exhaust of air diffusers. Measurement is conducted preferably at positions intended for intensive occupancy.
7. Description: The omni-directional heat wire probe is placed on a tripod into the position where the measure is intended. The tripod is meant not to influence the air flow and only then, the probe is turned on. Readings can be taken, once the measurement result on the probe is stable, not sooner.
8. Calculation: No calculation required.

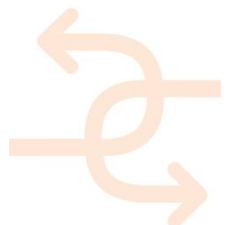

5.2.6 Test report on the measurements

For all measurement procedures, the report of the results shall contain the following information:

- Set points and permitted tolerances;
- Operating conditions such as load, control settings and weather conditions (if they influence the measurement results);
- Measuring locations and measuring points and drawings if necessary;
- Used measuring instruments and procedure;
- The measured values including date and time;
- Evaluation of the measurements (within or outside the permitted tolerances).

5.3 Identification of difficulties

5.3.1 Difficulties

Based on the previous sections, the inspection of a list of measurements is proposed to help the worker identify critical problems during the installation phase that might reduce systems' performance in the following stages of the building life causing delays, more intensive maintenance and/or increasing operating costs. Because the measurements need to be practical and simple, a few aspects, related to measurements of ventilation systems, need attention:

- **Time:** The key challenge of the inspection measurements lies in the time when the tests should be conducted. The ventilation system needs to be operational to evaluate the performance. But soon after putting the system into operation, the building will be delivered. During this last phase of the commissioning step, the most measurements will be conducted. Meaning that timing the measurements will be challenging, but important.
- **Conditions:** Measurements are conducted, regarding the conditions found in and outside the building. Some conditions, like temperate outside climate, can lead to troubled results. The best results will be achieved when conditions are at its limits (cold or hot weather and high thermal loads). So, in relation to timing, also the in- and outer conditions should be considered.
- **Accessibility:** Although the equipment may be suitable for operation on site, some parts of the ventilation system might be hard to access. For example parts of the duct system that is already covered by the ceiling. So, once again, timing in relation to the accessibility of ventilation parts is an important aspect.
- **Uncertainties:** Every measurement is always subject to an uncertainty which arises from the layout and method of measurement, the measuring equipment, and from taking the reading. The information on the uncertainty of the equipment is supplied by the instrument manufacturer and should not exceed the coverage probability of approximately 95 %. The uncertainty of method and taking the reading should be reduced to a minimum by using skilled people to carry out the measurements and provide them with adequate instructions.

Specifically there are some difficulties that can be related to a single measurement procedure. For example, in large and complex air duct systems, the ductwork leakage can only be measured in a part of the system.

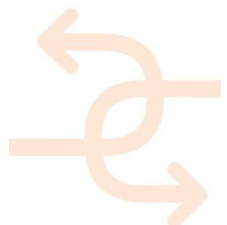

5.3.2 Limitations

Next to the difficulties, there are also some limitations to the inspection process of the ventilation system:

- The performance of the integrated ventilation facility cannot be measured since there is no thermal load and occupancy of rooms. The future appliances and occupants obviously have a great effect on the performance of the ventilation system, but cannot be simulated during the commissioning phase. The measurements results therefore are limited to the performance without thermal load and will only expose possible errors that influence critical performance. INSITER methodology acknowledges this limitation.
- Performance decrease along time and operation (e.g. due to abnormal fouling proliferation derived from any mistake during installation) cannot be estimated.
- The selected measurements, like stated before, do not fully cover all the necessary ventilation tests, but focus on the critical performance and quality indicators, as defined in D1.6.

Measurements will be carried out by skilled workers. This is not any different from the current practice, but nevertheless important to recognise that they are subject to regional legislation and possible practical restrictions.

5.4 Diagnosis and related KPIs

The purpose of this section is to define a procedure to diagnose the impact of measured deviations on the real performance of the ventilation system. Because of the mentioned limitations of the inspection stage, measurements taken on instant or relatively short tests are not directly representative for the real performance of the entire system.

Already mentioned in earlier chapters is to use energy simulation software to create a sensitivity analysis and correlate measurement results with the output of the simulation. Another way is to use the control system to analyse the reaction it gives to a certain change of input parameters. Because all KPIs will have to be analysed differently from the conducted measurements, the section below will give a more detailed description of the diagnosis.

KPI	Measurement protocol
Efficiency of heat transfer (EE)	Efficiency of heat exchanger
	Ductwork leakage
Efficiency of electrical components (EE)	Electrical power of the fan
	Pressure difference across air filter
Thermal Comfort (IEQ)	Indoor air velocity
	Air temperature
	Air humidity
Acoustic Comfort (IEQ)	Sound pressure level
Indoor Air Quality (IEQ)	Air flow rates
	CO ₂ -level

Table 12 : KPIs and related measurement protocols

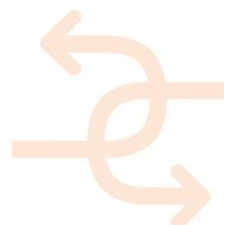

5.4.1 Simulation based analysis

As introduced in section 3.2., the simulation based self-inspection will be applied. For the ventilation system, it means that the following KPIs must be simulated by the design team, to determine their impact on the overall energy performance of the building.

- Efficiency of heat exchanger;
- Nominal power of the fan.

During this performance, the simulation software (Vabi Elements) is used to determine the impact and create a graph wherein the relation between the deviated KPI value is set against the overall energy consumption of the building.

Efficiency of heat exchanger

For the efficiency of a heat exchanger an example of a simulated building is given. On the x-axis the deviation to the design value for the efficiency of the heat exchanger is given. In this case, the heat exchanger has a design efficiency of 70%. So the 0% value corresponds to 70% efficiency, the -1% value to 69,3% efficiency, etcetera. On the vertical (y-) axis, the simulated impact on the energy consumption is given. In this particular case, a 10% poorer performance of the heat exchanger, leads to an energy consumption of 683076 kWh/year (1,8% higher energy consumption).

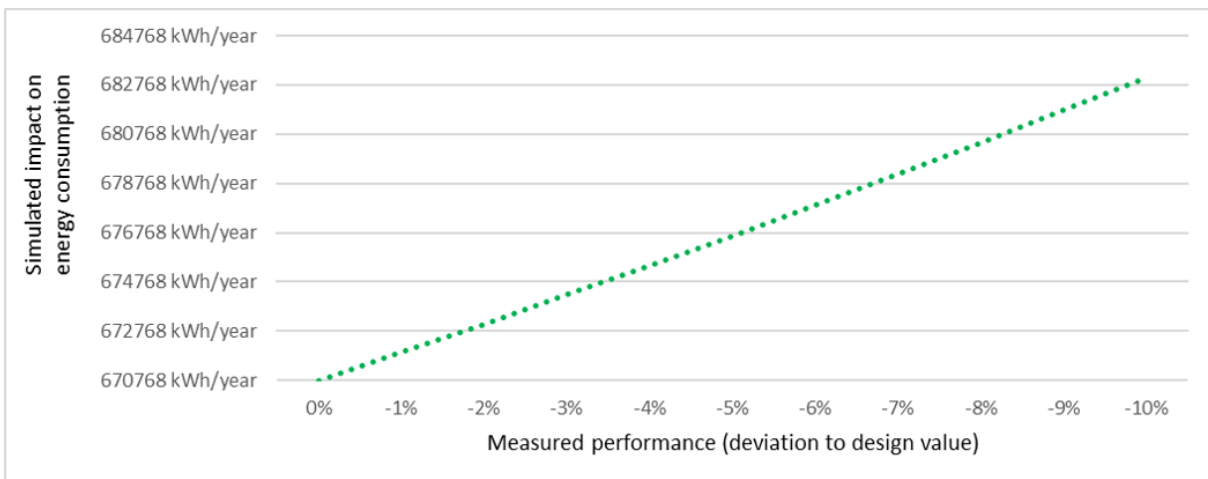
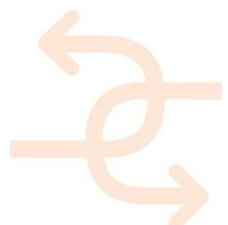

Figure 32: Relationship between measured performance and simulated impact on energy consumption

After simulating the relationship between measured efficiency of the heat exchanger and its impact on actual energy consumption of the building, the building designers together with commissioning experts have to agree and indicate the boundaries that determine the KPI threshold. For example, if agreed that the energy efficiency of the heat exchanger may not lead to an overall energy consumption deviation of 1% (boundary, about 677265 kWh/year), the threshold will be approximately 5,8% (see Figure 33).



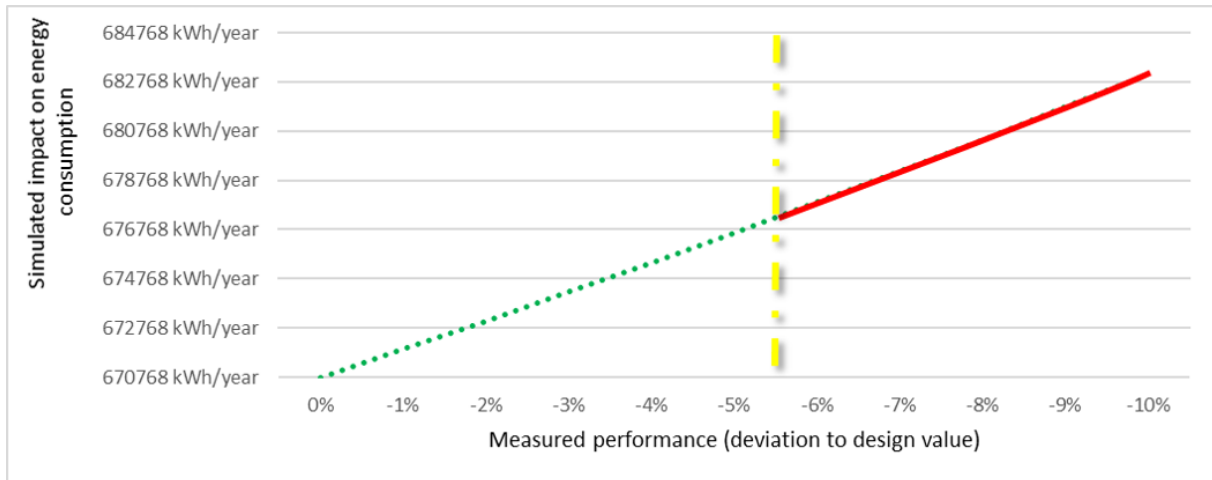
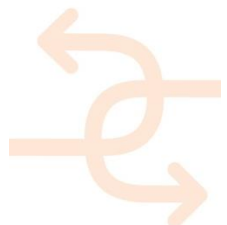

Figure 33: Threshold based on the simulation-based approach

During the construction phase, the heat exchanger performance measurements will be taken during the self-inspection process. The outcome of these measurements is then compared to the threshold from the simulated graph. In this particular case, a deviation of 5,8% less than the design value (70%), means rejection. This equals an approximate efficiency of the heat exchanger of 66%.

The measurement and calculation of the efficiency of the heat exchanger is difficult to measure under design conditions. It is not directly influenced by occupants or thermal load, but the efficiency is given for a certain air flow at fixed outdoor and indoor temperatures and humidity. Since we cannot influence the outdoor temperature and humidity, the measured values may deviate. To solve this problem, the easiest way is to measure the efficiency at two different outdoor conditions under constant indoor conditions and calculate the results into the design specifications. The steps of the proposed diagnosis procedure are:

- 1) Define test conditions in terms of load, air flow rates of return and supply air, return air temperature and humidity and the time and duration of the test (see Section 5.2.3). These values should meet the design specifications.
- 2) Measure and report the outdoor air temperature and humidity. This should be the only variable value.
- 3) Measure and report the supply and exhaust air temperatures and (if applies) moisture content and calculate the efficiency of the heat recovery exchanger.
- 4) Repeat step 3 at a different (minimum difference is 5 degrees Celsius) outdoor temperature and report the measured values.
- 5) The graph (outdoor temperature vs. efficiency of the heat exchanger) can be considered linear. This makes it possible to calculate the efficiency by extrapolation of the reported data towards the outdoor temperature, used at the design stage.



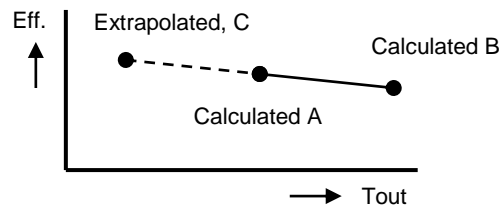

Figure 34 : Extrapolation of data to calculate the efficiency of the heat exchanger (Eff.)

Nominal power of the fan

The nominal power of the fan determines the energy use for ventilators. With a given fan control system and fan characteristic, a deviation to the design value of the nominal power will influence the energy use for ventilators and thus, the overall energy use of the building.

In the next example, we use a building with one air handling unit and two fans (return air fan and supply air fan). On the x-axis the deviation to the design value for the nominal power of the fans is given. In this particular case, the nominal powers of the supply air fan and return air fan are respectively 1880 and 1660 W, according to design specification. The 0% value corresponds with these design values. On the vertical (y-) axis, once again, the simulated impact on the energy consumption is given. In this case, a 10% higher power use of the fans, leads to an energy consumption of 45147 kWh/year (about 2,4% higher energy consumption) of the total building.

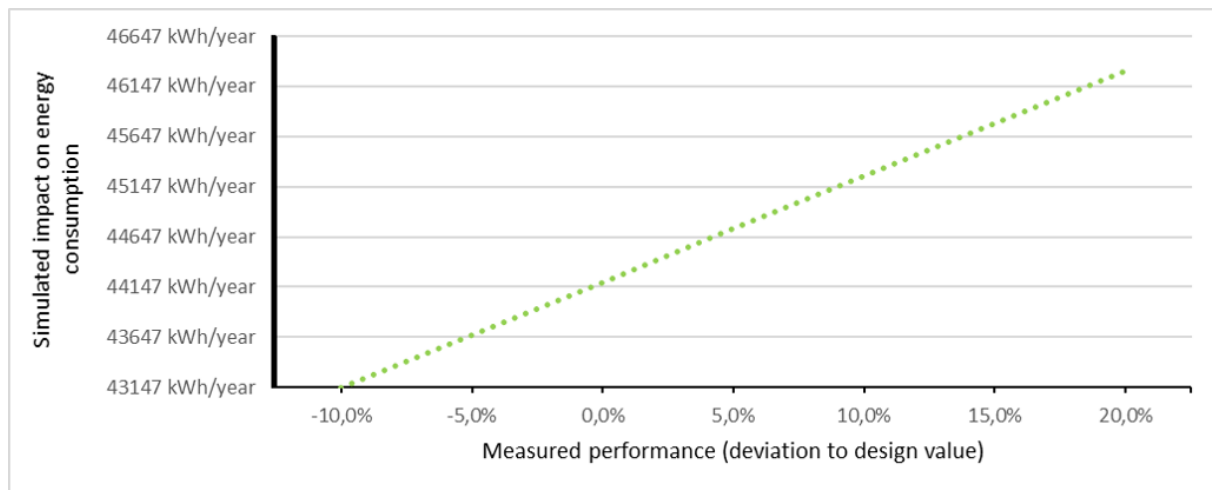
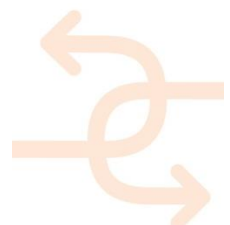

Figure 35: Relationship between measured performance and simulated impact on energy consumption

After simulating the relationship between measured power of the fans and its impact on actual energy consumption of the building, the building designers together with commissioning experts have to agree and indicate the boundaries that determine the KPI threshold. For example, if agreed that the power of the air fans may not lead to an overall energy consumption deviation of 1% (boundary) (about 44647 kWh/year), the threshold will be approximately 4,0% (see Figure 36).



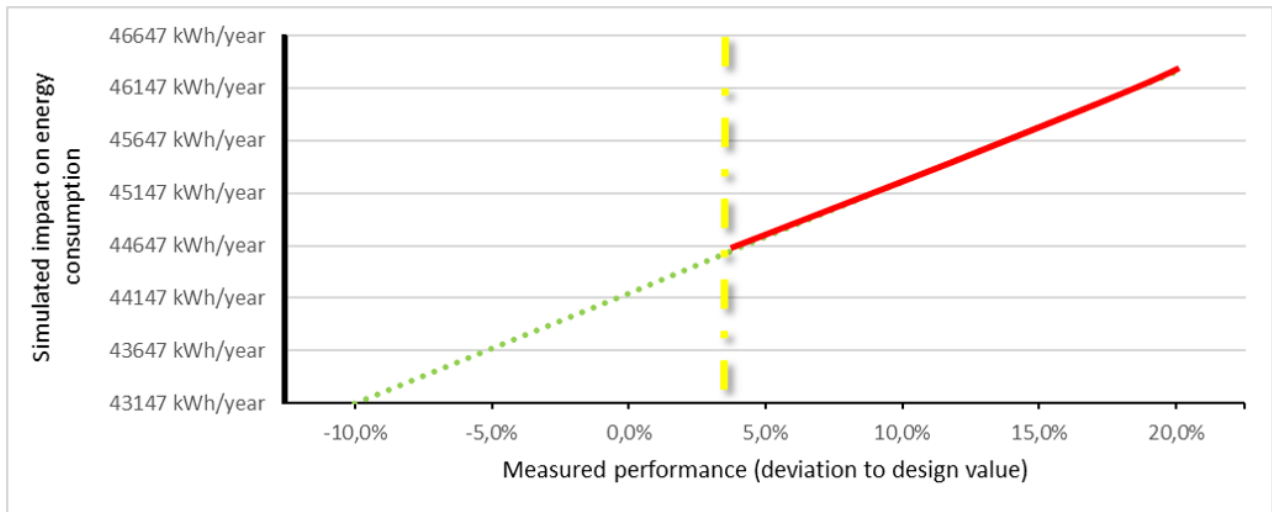

Figure 36: Threshold based on the simulation-based approach

During the construction phase, the power measurements will be taken during the self-inspection process. The outcome of these measurements are then compared to the threshold from the simulated graph. In this particular case, a fan power of 4,0% more than the design values, means rejection. This equals an approximate power of efficiency of the heat exchanger of 66%.

The nominal power of the fan depend on multiple aspects, where the pressure drop of the subsystem (supply or return air) is an unknown factor. However, there is a direct relation between the electrical power and pressure drop, defined by:

$$P_{el} = \frac{q_v \cdot p_{tot}}{\eta_{vent}}$$

Where,

- P_{el} is the electrical power of the fan in W;
- q_v is the air flow in m³/s;
- p_{tot} is the total pressure drop in Pa;
- η_{vent} is the efficiency of the ventilator (fan + motor).

The air flow should be set to design specification and the total pressure drop can be measured. From these values, the efficiency of the ventilator can be calculated and compared to the manufacturer's specification.



5.4.2 Thermal Comfort

The thermal comfort is, amongst other aspects, influenced by the:

- Indoor air velocity,
- Air temperature, and
- Air humidity.

All of these measurement aspects have a direct relation with occupancy of people and heat load of appliances and lighting in the room. The measurements, conducted before building delivery, do not include these in use conditions. Therefore the measurements can never be representative for the in use phase of the building. However, these measurement aspects can contribute to reveal possible errors in the control system. To exclude or solve these errors is in any case very valuable. Besides, if the measured values don't represent the design values, the deviation will be worse after building delivery.

For valuable results, the measurements should be conducted under different control settings, for example, at different room temperature settings and different air flow rates. The measurement results can be directly interpreted as key performance indicator, thermal comfort.

5.4.3 Acoustic Comfort

The acoustic comfort is defined by the measuring the sound pressure level in the room.

Although the sound pressure is influenced by occupancy of the room after building delivery, the main focus of these measurements is to exclude sound pressure, produced or derived through the ventilation system. So the measurements are more accurate with no distorting sounds influencing the measurements.

The sound pressure level is measured with the ventilation system working at design flow rates. The measured value is the key performance indicator for acoustic comfort. If other sounds need to be eliminated in the measurement, a second measurement will have to be conducted, with the ventilation system turned off. It has to be absolutely sure that the sound level pressure of surrounding sounds has not changed. Only then, next calculation to sum up sound levels can be used to calculate the sound level pressure of the ventilation system.

$$L_{\Sigma} = 10 \cdot \log_{10} \left(10^{\frac{L_1}{10}} + 10^{\frac{L_2}{10}} \right)$$

Where,

- L_{Σ} is the total sound pressure level in dB;
- L_1 is the sound pressure level of the first source (i.e. the ventilation system) in dB;
- L_2 is the sound pressure level of the second source (i.e. the measured background noise) in dB;

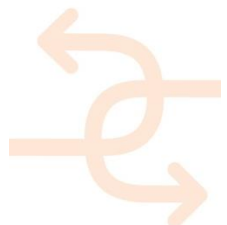

5.4.4 Indoor Air Quality

The thermal comfort is, amongst other aspects, influenced by the:

- Air flow rates, and
- CO₂-level.

The CO₂-level measurement before building delivery is not representative for the CO₂-level during the in use phase and there is no way to predict or simulate this. So this measurement will not be conducted within the INSITER scope, see also Table 14 in section 5.1.

The air flow rate in a room depends directly on the design air flow of the entire system (at the ventilation unit or air handling unit), and a correct adjustment of the system. So measuring the air flow rates in the rooms contributes to a correct operating ventilation system and can be conducted as stated in section 5.2.3 (central system) and 5.2.5 (in the room).

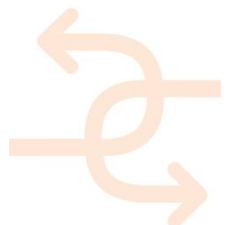

5.5 Thresholds and tolerances

The following reference thresholds and tolerances are defined in order to avoid unacceptable deviations on the performance of the ventilation system, as derived from INSITER measurement results.

A desired value (DV) is chosen as the ideal outcome to be obtained from each measured KPI, generally the design value. In addition, a tolerance range allows for uncertainty and limitations on the inspection tests, so, if the measurement result is within this tolerance range, the installation should be accepted. Otherwise, the installation should be rejected and additional measures would need to be taken to correct the detected faults.

KPI	Unit	Desired Value (DV)	Tolerance	Remarks
Efficiency of heat exchanger	-	Design	± 1 % on overall building EE	The simulated decision support chart is used to determine the acceptable tolerance of the efficiency of the heat exchanger.
Ductwork leakage	-	Design	Min. class B	Air tightness class according to EN 12237 and EN 1507.
Electrical power of the fan at design air flow rate	W	Design	± 1 % on overall building EE	The simulated decision support chart is used to determine the acceptable tolerance of the electrical power of the ventilation fans.
Pressure difference across air filter	Pa	Design	± 10 %	Since pressure difference will affect the electrical power of the fan, the filter might have to be replaced, even within the tolerance.
Air velocity in occupied zone	m/s	Design	± 0,05 m/s	Source: EN [14].
Air temperature in occupied zone	°C	Design	± 1,5 °C	Source: EN 12599 [14].
Relative humidity [RH]	%-RH	Design	± 15 %-RH	Source: EN 12599 [14].
A-weighted sound pressure level in the room	dB(A)	Design	± 3 dB(A)	If legal requirements or local building regulations demand closer uncertainties, this shall be specially defined in the inspection
Air flow rate, each (sub)system	m ³ /s	Design	± 10 %	Source: EN 12599 [14].
Air flow rate, each individual room	m ³ /s	Design	± 15 %	Source: EN 12599 [14].

Table 13 : Thresholds and tolerances for the ventilation system

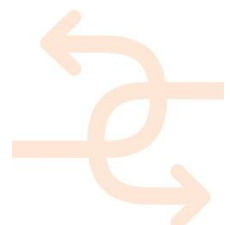

6. Solar hot water system

The last MEP/HVAC subsystem to be analysed concerns a solar hot water system, i.e. a solar thermal facility to capture renewable energy from the incident solar radiation and transfer it to a heat transfer fluid in order to produce hot water either for space heating or domestic hot water purposes. A typical solar hot water system is comprised by a set of individual energy equipment. The most relevant ones are: (i) the solar panels/collectors/field, (ii) the Heat Exchanger (HX), and (iii) the thermal storage tank. Additionally, many other auxiliary components are required (e.g. valves, pumps, pipes, pipe fittings, deaerators, expansion vessels, auxiliary buffer tanks, controllers, etc.)

These components can be connected according to many different configurations depending on the type of application, characteristics of the solar thermal panels, etc. Figure 37 and Figure 38 show two typical, basic, conceptual schemes that help address the analysis and measurement-supported inspection of this system.

The first one includes an external heat exchanger (HX) out of the thermal energy storage tank with two different circuits (primary/secondary) clearly identifiable.

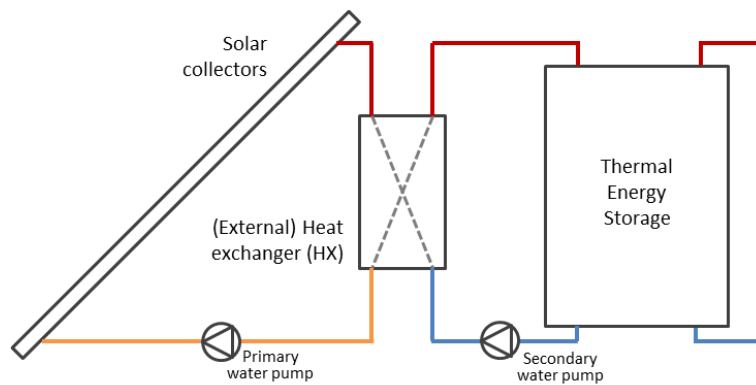

Figure 37 : Typical simplified solar hot water system diagram: option 1

The second one removes the external HX and is based on an internal coil-type HX which is located inside the main thermal energy storage tank. This way, heat losses are minimized and the number of some of the components is reduced (e.g. fluid pump)

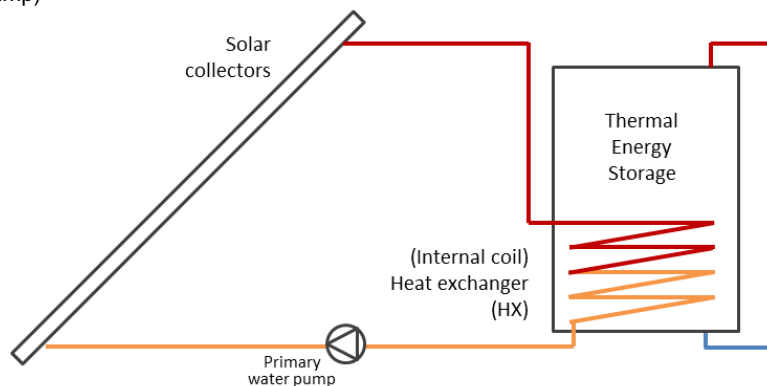
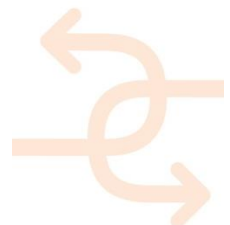

Figure 38 : Typical simplified solar hot water system diagram: option 2



Starting from this conceptual basis, this section addresses the description of a set of relevant indicators (Key Performance Indicators, KPIs) that will support a simplified practical methodology for the inspection of HVAC solar thermal facilities before the delivery of the building. Both the set of indicators as well as the adapted methodology for measurement and evaluation is described next.

This work stems from previous work in INSITER's D1.6 [1], where KPIs were defined on an abstract level including in-use (maintenance) phase of the building life-cycle. However, it was agreed that INSITER should focus on the processes before the delivery of the building itself. In this sense, this work also takes the reference of the 'Revised Overview of Key Performance Indicators' for the project, as presented by the Project Coordinator in November 2017 [2].

The inspection method based on creation of scenarios, as it is previously outlined for the heat pump system, is not directly applied here. On-site testing of a solar hot water system depends on uncontrollable variables (such as weather conditions) which should be observed and used at the best convenience to conduct representative tests, but which cannot be selected and fixed for scenario creation. Therefore, measurements for inspection of the solar hot water system are adapted in accordance to a reasoned practical methodology described in the following sections. Benefits and limitations of this procedure will be stated.

Relevant indicators, measurement protocols, devices and specifications are described next. Reasonable thresholds as well as diagnosis considerations and estimation of the potential impact of possible deviations are commented as well. Particularly, the simulation-based inspection approach defined in Chapter 3 is used at this final step to estimate the long-term relevance of the measured deviations during the inspection tests.

Finally, it is important to insist on the differences between the present approach and objectives and those from in-house HVAC equipment tests. In-house tests are performed by manufacturers according to detailed testing standards, enabling certification of the equipment performance as it leaves the factory. Such standards carefully define testing procedures whose results enable comparison between different equipment of the same kind. Controlled testing conditions and dedicated testing facilities are used to this purpose. However, the objective of this section is to propose a simplified practical procedure that can be applied on-site after installation and before building delivery to check that different processes from the factory to the final installed HVAC facility have been adequately conducted and have not modified the designed performance of the target systems.

6.1 Measurement protocols and related variables

According to the revised definition of Key Performance Indicators (KPIs) presented on November 2017 within the project activities [1], this section addresses the selection of KPIs and related measurements that are relevant for the on-site performance inspection process of a solar hot water system before the technical facilities (particularly MEP/HVAC systems) are put into full operation.

The purpose of these measurements is to minimize the risk of underperformance due to any possible failure during the installation and integration works. Thus, they will ensure that, after installation, the system achieves relevant design conditions and set points as specified.

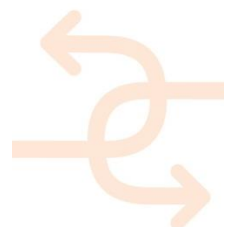

Table 14 presents those building related KPIs and measurement protocols concerning the solar hot water system:

KPI	Measurement protocol	Units	Description
Efficiency of heat/cold generation	Primary water supply temperature	C	Temperature of the primary water flow at the outlet of the solar field
	Secondary water supply temperature	C	Temperature of the secondary water flow at the outlet of the HX
	Solar collector efficiency	%	Collector efficiency (as the ratio between the useful energy transmitted to the fluid and the incident solar radiation) can be expressed in terms of temperature differences solar irradiance. Linear or 2nd-order polynomial relations can be considered
Efficiency of heat transfer	HX primary temperature difference	C	Temperature difference in the primary water flow between inlet and outlet of the HX
	HX secondary temperature difference	C	Temperature difference in the secondary water flow between outlet and inlet of the HX
	HX performance	%	HX performance can be expressed in terms of inlet/outlet temperatures and heat capacity of primary and secondary flows
Efficiency of heat/cold distribution	Primary water flow	kg/h	Water mass flow rate of the primary solar loop (between the solar field and the HX)
	Secondary water flow	kg/h	Water mass flow rate of the secondary loop of the overall solar system (between the HX and the thermal storage tanks)
Efficiency of electrical components	Primary pump electric power	W	Electric power consumed by the primary water pump
	Secondary pump electric power	W	Electric power consumed by the secondary water pump

Table 14: Relevant KPIs and related measurement protocols for the solar hot water system

The list of common errors during the construction phase is normally very large and some of them might affect systems' and building performance negatively. In order to detect and identify such difficulties, standard procedures include checklists and visual inspection, however quantitative intermediate checks before the building delivery are often missed. The inspection of the previous list of measurements is proposed to help the worker identify critical problems during the installation phase that might reduce systems' performance in the following stages of the building life causing delays, more intensive maintenance and/or increasing operating costs.

Table 15 lists those errors which the proposed measurements will help to identify during an improved commissioning stage. For instance, the purpose of this simple practical measurements is not just to check that a water pump can be turned on properly after installation, but to gain additional information that help rely on proper performance (e.g. adequate flow rate delivered and energy consumption) during upcoming operating phase.

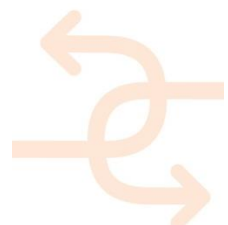

Measurement	Target fault/error to be identified
Primary water supply temperature	<ul style="list-style-type: none"> • Potential abnormal performance of solar panels • Design temperature conditions of the hot water supply not met
Secondary water supply temperature	<ul style="list-style-type: none"> • Potential abnormal HX or solar panels' performance • Design temperature conditions of the hot water supply not met
Solar collector efficiency	<ul style="list-style-type: none"> • Damage on solar collectors during the installation process (e.g. loss of vacuum conditions inside the tubes of evacuated panels) • Solar collectors not in accordance to design and manufacturer specifications (reduced thermal performance)
HX primary/secondary temp. difference	<ul style="list-style-type: none"> • Errors on pipe and fittings connections
HX performance	<ul style="list-style-type: none"> • Reduced heat transfer performance due to dirtiness, fluid channel blockage, etc. • Errors on pipe and fittings connections
Primary/secondary water flow	<ul style="list-style-type: none"> • Increased pressure drop in the circuits due to dirtiness, blockage, mounting faults or unexpected modifications on pipe layout linked to on-site spatial restrictions
Primary/secondary pump electric power	<ul style="list-style-type: none"> • Pumping elements not in accordance to design and manufacturer specifications (increased power consumption)

Table 15 : Target faults/errors to be identified through new inspection of measurements

6.2 Real measurements and related devices

The purpose of this section is to provide further details about the measurement variables and protocols required for the calculation and evaluation of the selected KPIs. Important aspects such as when (time planning), by whom (executer / responsible staff) and how (details of the measurement procedure, necessary devices, etc.) will be addressed next.

First, it should be noted that the identified measurements can be grouped in different levels according to the subsystem of the global MEP/HVAC facilities or, particularly, of the solar hot water system to which they are referred to.

The following levels are defined:

- **Generation:** it corresponds to the solar subsystems that allow obtaining a useful hot water flow to be then supplied to the terminal heating units or the end-use hot water consumption devices. This is mainly composed by the solar collector field. The main heat exchanger (if exists) might be also included within this level; however, here it was decided to define an additional level to that purpose.
- **Intermediate heat exchange:** it comprises the heat exchanger separating primary circuit (solar loop) and secondary circuit connected to the Thermal Energy Storage tanks.
- **Distribution:** this level comprises pipes, pumps and valves that allow supply/return of hot/cold water among the different energy components of the solar facility.
- **Storage:** it corresponds to the buffer tanks that allow storing heat from the solar collectors when solar availability and heating/hot water demands do not coincide in time.
- **Room:** this level is related to the end-use of the energy collected in the solar field. Indoor Environmental Quality (IEQ) and the quality of domestic hot water supply represent the final objective of the solar thermal system and would ideally enable the evaluation of adequate system functioning.

Table 16 shows the identified relevant measurements grouped into the previous levels as well as general comments related to the limitations that should be imposed to the application of such measurements:

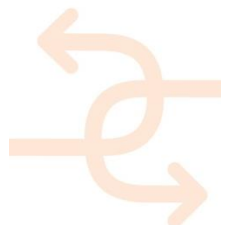

Measurement level	Limitations
Generation <ul style="list-style-type: none"> • Supply temperature • Collector efficiency 	(downstream solar collector and HX, if needed) (relevant boundary conditions must be ensured)
Intermediate heat exchange <ul style="list-style-type: none"> • Temperature differences in HX • HX performance 	(only as indirect measurements for HX performance) (corrections needed if primary/secondary fluids are different)
Distribution <ul style="list-style-type: none"> • Water flow rates • Energy use of water pumps 	(both primary and secondary circuits) (both primary and secondary circuits)
Storage	(irrelevant measured values during start-up/commissioning)
Room	(irrelevant measured values during start-up/commissioning)

Table 16: Measurement levels for the solar hot water system

It should be noted that no measurements are proposed at storage or room level since the INSITER scope focuses on the inspection process before building delivery, so irrelevant measurements would be obtained at such levels during this stage of the construction project. In order to get representative measurements from storage or room levels, the whole building facilities should be put into real operation for a relevant period of time, which makes no sense in this context.

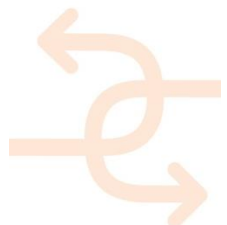

6.2.1 General procedure and considerations

Before starting the functional measurements, some actions should be taken. Being consistent with the approach presented for the ventilation and heat pump systems, Table 17 presents the list of relevant actions that considers appropriate specifications of the identified measurement protocols.

Action	Description
1 Determine the time and planning of measurements	Time and planning is crucial for INSITER's methodology.
2 Correlate the measurement to an executer	For each measurement, specify the level of competence and qualities needed to conduct the measurements.
3 Define test conditions and calculations	Functional measurements can take place at other conditions than design conditions. The measurements are allowed to be calculated into design conditions if the calculation is possible.
4 Select the measurement instrument(s)	For each measurement, one or more instruments are needed. The instruments will be selected based upon their usability on site, the accuracy (or uncertainty) and practical implementation in INSITER methodology. Only calibrated devices shall be used.
5 Define the number of measuring points	For certain measurements, it might be necessary to take multiple measurements at multiple locations. For example to measure the room temperature, depending on the size of the room.
6 Specify the measuring location(s)	The exact locations where the measurements are being carried out will be specified. This is about the location in relation to the HVAC/MEP-system or room and not the general locations in the building.
7 Perform measurement	Describe the actions needed to perform the measurements.
8 Calculations and input of measured values	If applies and if possible, measurements are allowed to be calculated into design conditions or into qualified values. Equations are given.

Table 17: Specifications of the measurement protocols: General procedure

One of the main critical aspects of this procedure is related to the **test conditions that should be ensured to obtain relevant results** from the solar hot water system inspection process. Two different categories of testing requirements should be considered:

- **Distribution components:** Those measurements associated to the 'distribution' level (i.e. water mass flow rates and water pump power consumption) can be measured in a simple test. It only requires opening all valves to enable maximum (design) water circulation through related circuits, turning on the pumps, and waiting just some seconds to check the target measurements. Hydraulics (but not the thermal behavior of the system) is the key issue in this context and testing conditions are less critical. The purpose of these tests is to check that the installation has been properly completed and that design water flow rates and expected pumping energy use values are met. In case there was any kind of mounting error, pipe obstruction, pump manufacturing fail. etc., results would be affected and these simple measurements would allow the executer to identify the problem.

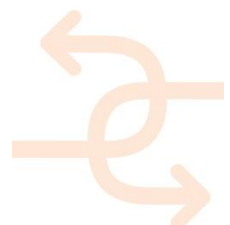

- Energy performance: The rest of the proposed KPIs and corresponding measurements are related to the energy performance of the system or particular components (e.g. collectors). In this case, the testing conditions involve more requirements since solar availability, energy losses and thermal inertia should be considered to obtain meaningful results and conclusions. General conditions to be guaranteed during the test are:
 - *Sunny weather*: These functional measurements need to be done under real (uncontrolled) solar conditions, which is a limitation. To minimize the impact, they should be performed under sunny weather conditions close to midday so that maximum availability of beam solar radiation can be ensured. Nonetheless, solar irradiation will be measured on the panel surface in order to allow for evident differences depending on the season/day of the year for the on-site checks.
 - *No shadings*: Shadings over the panels' surface must be avoided.
 - *Wind velocity*: The test should check that wind velocity is within a bounded range (to avoid infrequent convective losses). It is proposed to consider a range between 1 m/s and 4 m/s
 - *Cold storage*: The test should start from cold storage conditions in order to guarantee stable inlet conditions in the solar field and facilitate that testing conditions are met in this stage of the building project. (It makes no sense to define a test based on hot storage temperatures that need relatively long running periods to be reached; which is quite complicated before the building delivery).
 - *Test duration*: The thermal inertia of the collectors is relevant in this context, so dynamic effects should be considered carefully at the beginning of the test measurements. Irradiation, wind velocity and inlet temperature are 'controlled' in a narrow variation range if the previous conditions are checked; however, in order to obtain relevant data about the energy performance of the system, it is needed to wait for the output of the solar collector to reach acceptable stable conditions as well. 10-15 minutes is proposed as a reference test duration, although the required check for stable conditions (continuous monitoring during the test) may lead to slightly shorten/extend the test.

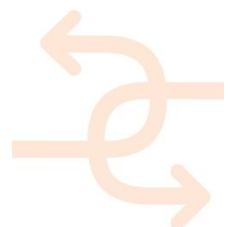

6.2.2 Generation systems

Primary water supply temperature

1. Planning: The primary water supply temperature should be measured during the commissioning of the solar hot water system.
2. Executer: The executer must have professional skills on installation and maintenance of HVAC systems. Knowledge about safety measures is relevant. Basic logical-thinking and communication skills are also required. Finally, national certificates may apply (e.g.: Spanish Catalogue of Professional Qualifications – CNCP. Related professional families: ‘Energy and water’, ‘Installation and maintenance’**Error! Reference source not found.**)
3. Condition: The ‘energy performance’ category for the relevant test conditions should be applied (see Section 6.2.1)
4. Instruments: Water temperature is measured with any dedicated standard RTD temperature sensor with thermowell. Correct calibration must be ensured. The sensor will be connected to a SCADA system or a portable data acquisition device. Another option can be based on the use of a heat meter, which will integrate flow and temperatures (inlet/outlet) probes (see Figure 39).
5. Number: One single measurement signal. Continuous measurement (e.g.: 5-10 seconds sampling rate) during the test is recommendable to check the temperature evolution and ensure that test conditions are met and the results are relevant.
6. Location: The measuring equipment should be connected to the solar loop in the water supply pipe as near as possible to the outlet connection terminals of the solar field. The layout of the measuring equipment and cables should be such that no errors due to interference from magnetic fields can occur. The cables should be of sufficient rating that an error is not introduced into the measured result.
7. Description: This temperature will be monitored along the whole test and checked in comparison with appropriate thresholds (see Section 6.5) when stable conditions are reached
8. Calculation: No indirect calculation should be done. A RTD temperature sensor is based on the change of the electrical resistance of a given conductor as a function of its temperature (linear relation can be normally assumed)

$$R = R_0 \cdot (1 + \alpha \cdot \Delta T)$$

The temperature of the sensor modifies an electric current signal. Then, it is conveniently processed, so the temperature value can be directly read from the SCADA or the data acquisition device. R_0 and α might have to be configured according to the specific type of RTD sensor being used.

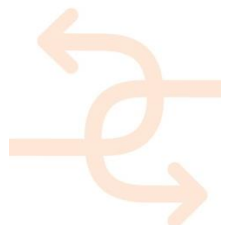

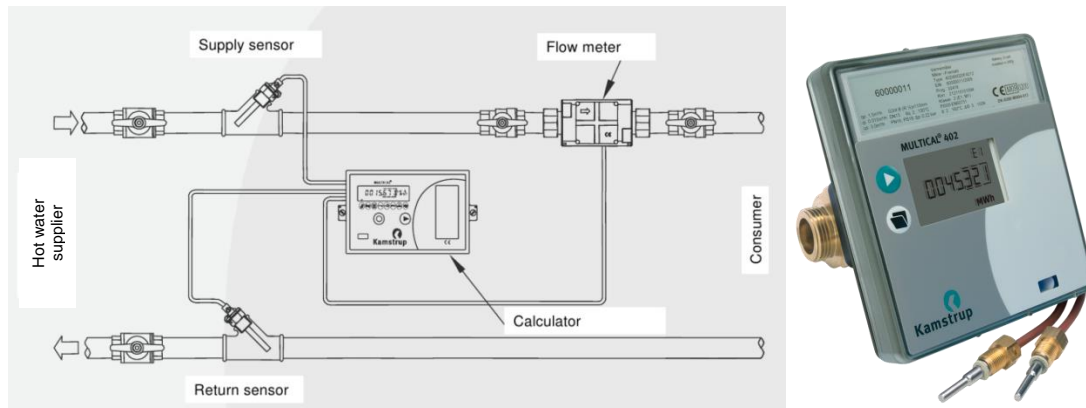
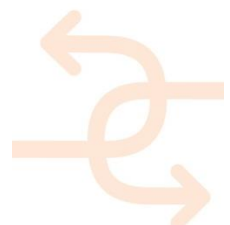

Figure 39 : Example of heat meter flow and temperature measurement assembly, Source: [7]

Secondary water supply temperature

1. Planning: The secondary water supply temperature should be measured during the commissioning of the solar hot water system.
2. Executor: The executor must have professional skills on installation and maintenance of HVAC systems. Knowledge about safety measures is relevant. Basic logical-thinking and communication skills are also required. National certificates may apply.
3. Condition: The 'energy performance' category for the relevant test conditions should be considered (see Section 6.2.1)
4. Instruments: Water temperature is measured with any dedicated standard RTD temperature sensor with thermowell. Correct calibration must be ensured. The sensor will be connected to a SCADA system or a portable data acquisition device. Another option can be based on the use of a heat meter, which will integrate flow and temperatures (inlet/outlet) probes (see Figure 27)
5. Number: One single measurement signal. Continuous measurement (e.g.: 5-10 seconds sampling rate) during the test is recommendable to check the temperature evolution and ensure that test conditions are met and the results are relevant.
6. Location: The measuring equipment should be connected to the load-side circuit of the Heat Exchanger. It will be placed in the thermal storage water supply pipe as near as possible to the load outlet connection terminals of the HX. If there were no intermediate HX, secondary supply temperature would make no sense and this parameter would not be determined.
The layout of the measuring equipment and cables should be such that no errors due to interference from magnetic fields can occur. The cables should be of sufficient rating that an error is not introduced into the measured result.
7. Description: This temperature will be monitored along the whole test and checked in comparison with appropriate thresholds (see Section 6.5) when stable conditions are reached
8. Calculation: No indirect calculation should be done. As explained before, the temperature value can be directly read from the SCADA or the data acquisition device.



Solar collector efficiency

- 1. Planning: The solar collector efficiency is one of the key variables of the inspection test. It should be measured during the commissioning of the solar hot water system.
 - 2. Executor: The executor must have professional skills on installation and maintenance of HVAC systems. Logical-thinking, communication and basic math skills are required. National certificates may apply. Knowledge about safety measures is also relevant.
 - 3. Condition: The 'energy performance' category for the relevant test conditions should be considered (see Section 6.2.1)
 - 4. Instruments: Different equipment is needed to determine solar collector efficiency: (i) Heat meter (mass flow sensor + inlet/outlet temperature probes) to determine the amount of energy transferred to the fluid; (ii) pyranometer to determine the incident solar energy on the collector surface; (iii) anemometer to measure wind velocity and check that the test is conducted under representative conditions; and (iv) ambient temperature probe to account for energy losses. A weather station (which will include solar radiation, wind velocity and ambient temperature monitoring) is strongly recommended.
 - 5. Number: Several sensors are needed (see above). The corresponding monitoring variables and signals are involved in the performance test.
 - 6. Location: The heat meter will measure fluid mass flow rate at the inlet of the collector field. Installation recommendations from the manufacturer concerning distance to singular hydronic components (such as valves or pipe elbows) should be considered. Supply and return temperature probes will be placed with thermowells (see Figure 39) as near as possible to the outlet/inlet ports of the solar field.
- Location (cont.): A tilted pyranometer will be installed at the same angle as the solar panels in order to measure irradiance on the collectors' plane (see Figure 40). A horizontal pyranometer can be added for global horizontal irradiance (GHI) measurements.



Figure 40 : Example of location of tilted solar pyranometer, source: [8]

Ambient temperature and wind velocity measurement equipment will be placed in the near surroundings of the collectors field at a similar height (i.e. since there might be relevant differences on wind velocity values depending on height location, if a roof solar installation is involved, the weather station or the dedicated anemometer will be placed on the roof).

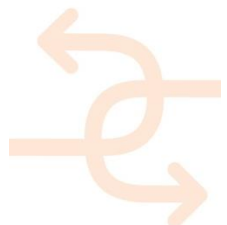

7. Description: General conditions concerning 'energy performance' test duration should be guaranteed. Thus, the solar loop water pump will be turned on with fully open valves (design conditions; no flow regulation). After flow rate checks (see water flow measurements below) all the involved monitored variables are observed. If test validity conditions (sky condition, wind velocity range, etc.) are fulfilled and stable conditions are reached, their steady-state values are registered and the indirect calculation of the collector thermal performance is done.
8. Calculation: Simple indirect calculation based on the measured variables is needed. Solar collector thermal efficiency correlates the useful energy transferred to the heat carrier to the incident solar energy on the collector surface. Efficiency will be different depending on boundary conditions. Indeed, a linear or second-order relation (see below) is normally provided by manufacturers according to in-house performance tests following standard ISO 9806. Coefficients η_0, a_1, a_2 are known from manufacturer specifications. The purpose of inspection is to check that (after installation) collector performance is close to that claimed by manufacturers.

$$\eta_{col} = \frac{E_{useful}}{E_{solar}} = \frac{\dot{m} \cdot c_p \cdot (T_{out} - T_{in})}{I \cdot S} = \eta_0 - a_1 \cdot \left(\frac{T_m - T_a}{I}\right) - a_2 \cdot I \cdot \left(\frac{T_m - T_a}{I}\right)^2$$

Where:

\dot{m} = fluid mass flow rate (kg/s)

c_p = fluid specific heat capacity (J/kgK)

T_{in} and T_{out} = fluid inlet and outlet temperatures (°C)

T_a = Ambient air temperature (°C)

I = solar global irradiance (W/m²)

S = collector surface (m²)

6.2.3 Intermediate heat exchange

Heat Exchanger (HX) primary temperature difference

1. Planning: Primary Temperature Difference (PTD) at the HX is a relevant measurement that will contribute to: (i) check the energy losses within the primary solar loop (between the solar field and the HX) through comparison with inlet/outlet fluid temperature values at the solar field; (ii) instantly detect heat transfer faults; and (iii) enable calculation of HX efficiency. It should be measured during the commissioning of the solar hot water system.
2. Executor: The executor must have professional skills on installation and maintenance of HVAC systems. Basic logical-thinking and communication skills are required. National certificates may apply. Knowledge about safety measures is also relevant.
3. Condition: The 'energy performance' category for the relevant test conditions should be considered (see Section 6.2.1)

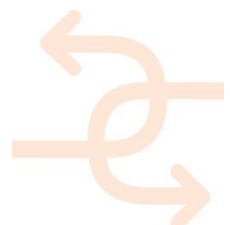

4. Instruments: Dedicated temperature probes or integrated temperature measurements from a heat meter can be used. Either way, fluid temperature is measured with any standard RTD temperature sensor with thermowell (although other options such as thermocouples are also possible). Correct calibration must be ensured. The sensors will be connected to a SCADA system or a portable data acquisition device.
5. Number: Two temperature signals (inlet/outlet) will be processed.
6. Location: Ideal location of temperature probes will be at the inlet and outlet pipes of the HX as close as possible to the corresponding source connection ports. However, since heat loss in the supply pipe (solar field to HX) should not be relevant, in order to optimize monitoring one single heat meter might be used to measure this 'primary temperature difference' as well as the 'primary water supply temperature' (see above). If this option can be selected, temperature probes between the solar field and the HX can be placed at any location in the supply/return pipes of the solar loop.
7. Description: These temperatures will be monitored along the whole test and checked in comparison with appropriate thresholds (see Section 6.5) when stable conditions are reached
8. Calculation: Very basic calculation is needed, since this measurement is the difference between inlet and outlet fluid temperatures at the source side (primary circuit) of the intermediate HX (if it exists):

$$PTD_{HX} = T_{HX,source,in} - T_{HX,source,out}$$

Heat Exchanger (HX) secondary temperature difference

1. Planning: Secondary temperature difference at the HX is a relevant measurement that will contribute to: (i) instantly detect heat transfer faults; and (ii) enable calculation of HX efficiency. It should be measured during the commissioning of the solar hot water system.
2. Executor: The executor must have professional skills on installation and maintenance of HVAC systems. Basic logical-thinking and communication skills are required. National certificates may apply. Knowledge about safety measures is also relevant.
3. Condition: The 'energy performance' category for the relevant test conditions should be applied (see Section 6.2.1)
4. Instruments: Dedicated temperature probes or integrated temperature measurements from a heat meter can be used. Either way, fluid temperature is measured with any standard RTD temperature sensor with thermowell (although other options such as thermocouples are also possible). Correct calibration must be ensured. The sensors will be connected to a SCADA system or a portable data acquisition device.
5. Number: Two temperature signals (inlet/outlet) will be processed.
6. Location: Ideal location of temperature probes will be at the inlet and outlet pipes of the HX as close as possible to the corresponding load connection ports.
7. Description: These temperatures will be monitored along the whole test and checked in comparison with appropriate thresholds (see Section 6.5) when stable conditions are reached

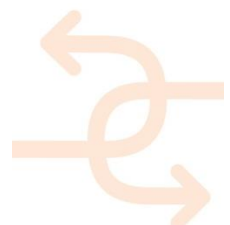

8. Calculation: Very basic calculation is needed, since this measurement is the difference between outlet and inlet fluid temperatures at the load side (secondary circuit) of the intermediate HX (if it exists):

$$STD_{HX} = T_{HX.load,out} - T_{HX.load,in}$$

Heat Exchanger (HX) performance

1. Planning: HX performance is quantified through the thermal effectiveness of the equipment. This measurement will be carried out during the commissioning of the solar hot water system.
2. Executor: The executor must have professional skills on installation and maintenance of HVAC systems. Logical-thinking, communication and basic math skills are required. National certificates may apply. Knowledge about safety measures is also relevant.
3. Condition: The 'energy performance' category for the relevant test conditions should be considered (see Section 6.2.1)
4. Instruments: HX thermal effectiveness requires collection of several fluid temperature measurements. Then, dedicated temperature probes (RTD or thermocouples) or temperature sensors integrated into heat meters can be used. As it will be explained below, fluid mass flow rates might be needed if source and load fluids are not the same. In that case, the use of heat meters are preferred and recommended. Correct calibration must be ensured. If dedicated temperature probes are used, they should be connected to a SCADA system or a portable data acquisition device. If the heat meter option is chosen, integrated displays can be used in order to annotate testing results.
5. Number: Four temperature measurements will be needed (source inlet/outlet, load inlet/outlet). Additionally, two fluid flow rate measurements (source/load) might be required.
6. Location: Temperature probes will be located at primary/secondary circuits as close as possible to the corresponding inlet/outlet HX connection ports. In case that fluid flow measurements need to be included, manufacturer guidelines concerning sensor placement should be considered (particularly in order to account for minimum distances between flow sensors and hydronic singular components).
7. Description: These temperatures (and fluid flow rates, if needed) will be monitored along the whole test. This will enable continuous HX performance computation along the test as well as check in comparison with appropriate thresholds (see Section 6.5) when stable conditions are reached.

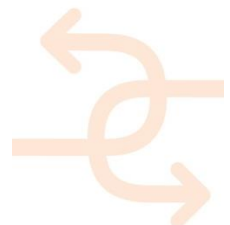

8. Calculation: The thermal effectiveness of the HX can be defined as the relation between the amount of actual heat transfer rate and the maximum heat transfer that would be physically possible when hot and cold fluid streams enter the HX. Source inlet temperature represents the maximum achievable load supply temperature and load inlet temperature represents the minimum possible source return temperature.

$$\varepsilon_{HX} = \frac{\dot{Q}_{transfer}}{\dot{Q}_{max}} = \frac{\dot{m}_s \cdot c_p \cdot (T_{s,in} - T_{s,out})}{\dot{m}_{min} \cdot c_p \cdot (T_{source,in} - T_{load,in})} = \frac{\dot{m}_l \cdot c_p \cdot (T_{l,out} - T_{l,in})}{\dot{m}_{min} \cdot c_p \cdot (T_{source,in} - T_{load,in})}$$

Where:

ε_{HX} = HX thermal effectiveness (-)

$\dot{Q}_{transfer}$ = Actual heat transfer rate (W)

\dot{Q}_{max} = Maximum achievable heat transfer rate (W)

\dot{m} = mass flow rate

\dot{m}_{min} = mass flow rate of the heat transfer fluid with lower heat capacity

c_p = specific heat capacity of the corresponding fluid

's' and 'l' are subscripts that refer to source and load fluids

- Calculation (cont.) If both fluids (source and load side fluids) are identical, HX thermal effectiveness can be calculated only in terms relevant temperatures, as follows:

$$\varepsilon_{HX} = \frac{\dot{Q}_{transfer}}{\dot{Q}_{max}} = \frac{(T_{s,in} - T_{s,out})}{(T_{source,in} - T_{load,in})} = \frac{(T_{l,out} - T_{l,in})}{(T_{source,in} - T_{load,in})}$$

6.2.4 Distribution components

Primary water flow

1. Planning: The primary water supply flow rate should be measured during the commissioning of the solar hot water system. However, no relevant inertia effects need to be considered, so the measurement can be done right after turning the fluid pump on (with fully open valves to provide design conditions).
2. Executor: The executor must have professional skills on installation and maintenance of HVAC systems. Knowledge about safety measures is relevant. Basic logical-thinking and communication skills are also required. Finally, national certificates may apply
3. Condition: The 'distribution components' category for the relevant test conditions should be applied (see Section 6.2.1)
4. Instruments: Dedicated individual fluid flow sensors might be used. However, since related fluid temperature measurements are also required along the test, the use of a heat meter with integrated flow rate measurement is recommended.
5. Number: One heat meter will be used.
6. Location: Integrated primary flow rate sensor will be placed on the supply pipe between the solar field and the HX.

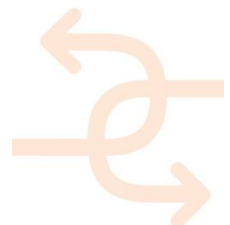

7. Description: First, all valves within the primary solar loop will be opened. Then, the primary fluid pump will be turned on under nominal (design) speed condition. Direct measurement will be gathered and compared with appropriate thresholds (see Section 6.5). Deviations (together with the analysis of pumps electric use) will allow detecting faults on the pumping systems and/or during the manufacturing and installation phases (e.g. leading to modified pressure drop magnitude in respect to design). Mounting errors, dirtiness inside the fluid loop, possible manufacturing errors on solar collectors and/or HX, etc. are the main target of this inspection.
8. Calculation: Primary water flow measurement will not be directly considered. As outlined in INSITER's D1.6, this is defined as an indicator relative to the 'set' or design value of the primary fluid flow rate. Then:

$$\dot{m}_p = \frac{\dot{m}_{p,measured}}{\dot{m}_{p,SET}} [\%]$$

Secondary water flow

1. Planning: The secondary water supply flow rate should be measured during the commissioning of the solar hot water system. The measurement can be done right after turning the fluid pump on.
2. Executor: The executor must have professional skills on installation and maintenance of HVAC systems. Knowledge about safety measures is relevant. Basic logical-thinking and communication skills are also required. Finally, national certificates may apply
3. Condition: The 'distribution components' category for the relevant test conditions should be applied (see Section 6.2.1)
4. Instruments: The use of a heat meter with integrated flow rate measurement is recommended.
5. Number: One heat meter will be used.
6. Location: Integrated secondary flow rate sensor will be placed on the supply pipe between the HX (if it exists) and the thermal storage tanks.
7. Description: First, all valves within the secondary loop (HX to storage) will be fully opened. Then, the secondary fluid pump will be turned on under nominal (design) speed condition. Direct measurements will be gathered and compared with appropriate thresholds (see Section 6.5). Deviations (together with the analysis of pumps electric use) will allow detecting faults on the pumping systems and/or during the installation phase (e.g. leading to modified pressure drop magnitude in respect to design). Mounting errors, dirtiness inside the fluid loop, possible manufacturing errors on the HX, etc. are the main target of this inspection.
8. Calculation: Secondary water flow measurement will neither be directly considered. As outlined in INSITER's D1.6, this is defined as an indicator relative to the 'set' or design value of the secondary fluid flow rate. Then:

$$\dot{m}_s = \frac{\dot{m}_{s,measured}}{\dot{m}_{s,SET}} [\%]$$

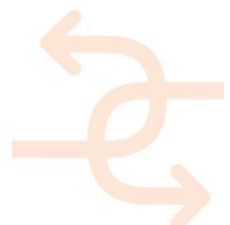

Primary/Secondary pump electric power consumption

1. Planning: The primary/secondary pump electric power consumption should be measured during the commissioning of the solar hot water system. The measurement can be done right after turning the fluid pump on.
2. Executor: The executor must have professional skills on installation and maintenance of HVAC systems. Knowledge about safety measures is relevant. Basic logical-thinking and communication skills are also required. Finally, national certificates may apply
3. Condition: The 'distribution components' category for the relevant test conditions should be applied (see Section 6.2.1)
4. Instruments: The electrical power consumed is measured either directly by a power meter (watt-meter) or indirectly from the electrical work (kWh-meter) performed by taking the electric meter readings before and after the test. For measuring the power instrument transformers, power meters and electricity consumption meters of an accuracy up to $\pm 1,0$ W shall be used.
5. Number: One single meter can be used. Multi-channel measuring devices can integrate primary and secondary pumps power use into the same equipment.
6. Location: The power meter should be connected to the related electric cabinet according to the updated electric scheme of the project.
7. Description: The wattmeter is an instrument that uses voltage and current to determine power in watts. For a single-phase two-wire circuit, one wattmeter with one voltage and one current measurement is sufficient. In case there were three-phase motors, two watt-meters (or channels) per pump would be needed.
8. Calculation: Watt-meter 1 gives electrical power P_1 with:

$$P_1 = U \cdot I \cdot \cos(-30^\circ + \varphi)$$

Watt-meter 2 gives electrical power P_2 with:

$$P_2 = U \cdot I \cdot \cos(30^\circ + \varphi)$$

The total electrical power P_e is given by P_1+P_2 .

Additional calculation is proposed for these measurements in order to provide meaningful information for inspection. Then, they are defined as an indicator relative to the design value of the pump electric consumption according to the manufacturer specifications:

$$P_e = \frac{P_{e,measured}}{P_{e,design}} [\%]$$

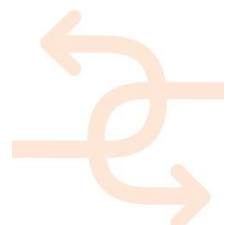

6.3 Identification of difficulties

6.3.1 Scope of INSITER measurements and limitations of the inspection process

Along the whole building life cycle, different measurements can be proposed with different purposes depending on the specific stage of the process that is targeted: components and material reception, construction, commissioning, in-use phase, etc. The value and requirements of such measurements are completely different depending on the purpose.

INSITER focuses on that stage right after the installation of building components (and MEP/HVAC systems in this particular case of D1.7) and before the building delivery, addressing the quality assurance of the installation of solar thermal systems.

The key challenge of the inspection measurements lies in the time when the tests should be conducted. This process is done at the commissioning step, aiming not only to check that systems is ready for operation, but to check that their performance can be estimated within acceptable margins in comparison to expected design values.

However, performance estimation should face several difficulties related to controllability of the testing process as well as to the available time period. In this sense, differences between in-house, in-use and INSITER measurements and possibilities become evident, thus revealing the gaps in performance that cannot be measured / inspected within the project scope:

- **In-house tests:** They refer to performance tests done by the manufacturer at the factory before the product or equipment delivery. They are based on well-established standard testing procedures that enable comparison of similar systems and provide guarantee of the reported performance. Proper facilities are used in order to control the testing conditions. No relevant time restriction applies.
- **In-use tests:** These correspond to the real-time measurements of the equipment performance during full normal operation conditions. Then, they are related to maintenance of the solar system. Boundary conditions cannot be controlled in this case, but real seasonal information about the system's behaviour is obtained (which directly represents the real impact of target systems on the building performance and use of resources).
- **INSITER tests:** According to the scope of the INSITER tests previously mentioned, important limitations should be considered. On one hand, there are time restrictions during the commissioning phase, so INSITER inspection measurements cannot count on long periods to wait for ideal testing conditions. At the same time, the target systems are available as installed on-site, without specific testing workbenches or dedicated facilities to control testing conditions. In fact, testing conditions cannot be controlled and must be adapted to the existing site/ambient variables (i.e. weather, spatial location, etc.). On the other hand, as long testing periods are not possible, performance values representative of weighed seasonal operation is neither possible. Then, extrapolation of measurement results should be devised to estimate real impact of performance deviations.

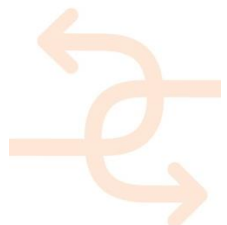

According to this, the following limitations on the inspection process of the solar hot water system can be mentioned:

- Performance of the integrated facility cannot be measured since there is no building energy demand at this stage and not all the MEP/HVAC systems are turned on as in full operation. In the same sense, the effects of the interaction with the building demand can neither be observed.
- Performance decrease along time and operation (e.g. due to abnormal fouling proliferation derived from any mistake during installation) cannot be estimated.
- The achievement of design objectives cannot be evaluated, since seasonal performance can only be extrapolated from very limited tested operating points.
- Expert workers in solar thermal systems do not usually carry out the installation process, so often there is a lack of analytical skills (on-site) related to specific HVAC performance issues.

Finally, in addition to the aforementioned challenges or difficulties, the final analysis of the performance is not always an easy task where the lack of tools is one of the problems. Some solar thermal facilities are not sufficiently monitored to extract useful data to assess the performance. Moreover, it has been observed that the KPIs are sometimes badly defined and their importance is vital for the proper evaluation of the final performance. Although the definition of these sensor networks is out the scope of the INSITER project, the capability of integrating tools for monitoring and visualization, as well as calculation of KPIs according to the well-established ones in this document, would relieve the mistakes produced at this stage.

According to all the previous arguments, the present document proposes reasoned **simplified practical measurement** protocols that can be adapted to the limitations of the inspection schedule, resources and boundary conditions within the INSITER scope, and, at the same time, can provide valuable information for fault detection, quality assurance and impact estimation on the performance of the solar hot water system according to the proposed **simulation-based self-inspection approach**.

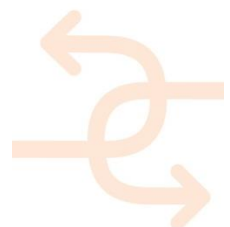

6.4 Diagnosis and related KPI's

The purpose of this section is to define a procedure to diagnose the impact of measured deviations on the real performance of the solar hot water system. Because of the evident limitations of the inspection stage, measurements taken on instant or relatively short tests are not directly representative of expected deviations on real performance. Reasoned planning of the testing process and assumptions for results interpretation will support the decision making of the involved workers and avoid unacceptable underperformance in future steps of the building operation.

In the precedent sections, thermal efficiency of solar collectors has been identified as one of the key performance measurements of the solar hot water system. To understand the impact of deviations on the efficiency measurements of the solar collectors (as-built vs. as-designed), which might be the consequence of accidental events or defaults during the installation process, a sensitivity analysis was performed using energy simulation software (TRNSYS). Figure 38 shows the new diagnosis approach for the solar hot water system

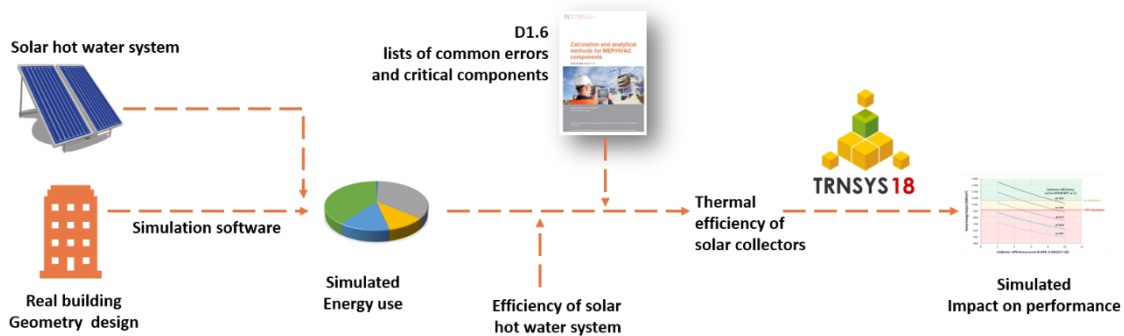
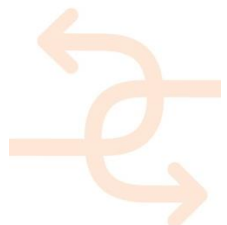

Figure 41: the new simulation-based diagnosis approach for the solar hot water system

The INSITER simulation-based self-inspection approach presented in this document was applied; however, the following particularities deserve further explanations:

- TRNSYS was used as the simulation tool to derive the sensitivity analysis because of the higher level of expertise of the responsible partners with this kind of software.
- The solar collector's efficiency is not a fixed parameter which can be directly measured and used as a single input for the simulation-based impact assessment. On one hand, it is indirectly calculated from temperature, flow and solar irradiance measurement values. On the other, solar panels are normally characterized by linear performance curves which represent the thermal efficiency of the panel depending on the temperature and solar radiation conditions. These facts require to account for some differences (in comparison to the HP case explained in Chapter 4) when applying the simulation-based approach. Such considerations are explained next.



6.4.1 Simulation-based self-inspection for solar hot water collectors

In the case of solar thermal collectors a simple way of estimating the impact of measured deviations on long-term performance is to derive approximate collector efficiency or power output curve from on-site measurements during the inspection process, and then determine the impact of potential deviations in comparison to design curves according to previously simulated results for the annual energy production, based on typical climatic profiles.

The performance curve of a solar thermal panel represents its thermal efficiency (η) (i.e. the ratio between the useful energy delivered to the fluid and the total incident solar radiation) in terms of a normalized independent variable (T^*), which accounts for the fluid and ambient operating temperatures as well as for the level of irradiance. The following definitions apply:

$$\eta = \frac{E_{useful}}{E_{incident}} = \frac{\dot{m} \cdot c_p \cdot (T_{f,out} - T_{f,in})}{I \cdot A} = a - b \cdot T^*$$

Where \dot{m} (kg/s), c_p (kJ/kgK), $T_{f,in}$ (C) and $T_{f,out}$ (C) are the fluid flow rate, specific heat capacity, and inlet/outlet temperatures respectively, I (W/m²) is the solar irradiance, A (m²) is the effective panel surface and 'a' and 'b' are characteristic constant and slope of the performance curve.

$$T^* = \frac{(T_m - T_a)}{I}$$

Where T_m (C) is the fluid average temperature within the solar panel, T_a (C) is the ambient temperature and I (W/m²) is the solar irradiance.

Therefore, a given solar thermal collector is not only characterised by a single value of thermal efficiency, but by a performance curve (normally linear correlations provide accurate enough performance estimations), which will be provided by the manufacturer as a design output. The constant term ('a') represents the optical efficiency (related to material properties) and is not affected by heat losses. The slope of the linear curve represents a 'heat loss coefficient'; the higher the slope is, the bigger efficiency loss will take place when the collector operates at high temperature differences or low solar radiation levels. A good solar collector will have a curve with high optical efficiency and very low slope, then being able to keep performance almost unaffected under all kind of operating conditions. An inefficient solar collector will have moderate optical efficiency and relevant slope, so its performance will sensibly decrease when the boundary conditions are not favourable. There are many different technologies and collector models in the market. A reasonable, typical performance curve can be considered: constant (a) = 0.8; slope (b) = 4 W/m²K.

Figure 43 shows a set of performance curves corresponding to example solar thermal collectors with identical optical efficiency (a = 0.8) and different heat loss coefficients or curve slopes ranging within b = 2-10 W/m²K

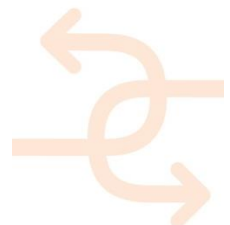

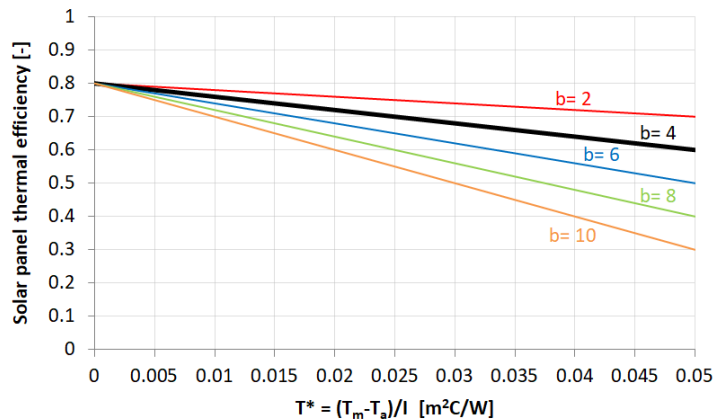
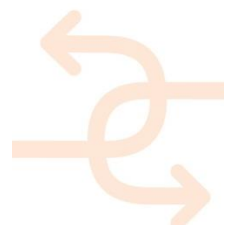

Figure 42: Performance curves for solar thermal collectors with $\eta_0 = a = 0.8$ and different 'heat loss' coefficients ranging from 2-10 W/m^2C

Based on the measurements identified within this document, it is possible to derive a specific value of the solar panel thermal efficiency for a single test (linked to a given set of testing conditions). However, since performance greatly depends on operating conditions, one single value it is not representative enough to extrapolate to its long-term performance. Panel's thermal efficiency should be then measured in at least two different conditions, in order to determine the performance curve (constant and slope) and then use such values as inputs for the simulation-based assessment of potential deviations. For all these reasons, the **steps of the proposed simulation-based self-inspection procedure** are:

- 1) Create the simulation model and the simulation-based decision-support material.**
 - a. Set up a simulation model to calculate the yearly thermal yield of one solar thermal collector or collector field.
 - b. Perform the sensitivity analysis (by modifying the characteristic curve coefficients of the simulated solar thermal panel, and generate the decision-support graphs for the onsite workers.
- 2) Select and conduct appropriate on-site measurements**
 - a. Define test conditions in terms of irradiation, air velocity, inlet temperature and duration of the test in order to reach representative testing conditions (see Section 6.2.1)
 - b. Measure outlet temperature under two different operating conditions through modification of mass flow rate from design value (point 1) to minimum value (point 2).The collector's performance should be calculated in two different 'operating points' in order to derive the linear performance correlation. After first calculation (with design flow rate), the water pump velocity is reduced to decrease fluid flow rate to 50% of the design condition. This way, the supply temperature should increase. Again the testing procedure is repeated: once stable conditions are reached relevant variables are registered and the collector performance for the two testing conditions is calculated.
- 3) Compute the characteristic performance curve measured on-site**
 - a. From mass flow rate and outlet temperature measurements (since the rest of parameters during the tests are assumed constant), on-site approximate collector output curve can be derived at this stage.



4) Use the decision-support charts to estimate the long-term impact of those measured deviations

- a. Make the comparison of the 'as-designed' and 'measured' thermal output curves on the basis of the decision-support chart generated in Step1. This chart correlates the yearly thermal yield of the target solar panel with the coefficients of the performance curve.

5) Make the final decision: Accept/Reject the commissioning of the solar hot water system

This procedure will support the worker to make the right on-site decision based on the possibility to easily self-inspect the proper behaviour of the system, which is one of the ultimate objectives of INSITER. Moreover, the proposed steps are of general application to different geographical sites (thanks to the simulation of relevant weather conditions when creating the decision-support material) as well as to any solar hot water system. The impact of potential deviations on the yearly energy output of the solar field is directly chosen to support the workers' decision since the good or bad performance of the target solar hot water system does not depend on the other facilities of the building. In addition, it is possible to relate the particular performance of the solar subsystem to the overall energy efficiency (EE) of the building thanks to the common initial step of the methodology described in Section 3.2.1 *"understanding building performance and major influencing systems"*.

6.4.2 Practical application example of the simulation-based self-inspection approach

To conclude, a simple example is presented next in order to illustrate the aforementioned simulation-based diagnosis procedure. To this purpose, a collector field with the following as-designed characteristics was used:

- Panel gross area = 2 m²;
- Performance curve: $\eta_0 = 80\%$; slope = -5.1 W/m²C

Step 1.- The as-designed performance curve of the example solar collectors is $\eta = 0.8 - 5.1 \cdot T^*$. In this first step of the diagnosis approach, performance deviations related to a range of curves with a = 0.5 – 0.9 and b = 2 – 10 W/(m²C) were simulated in TRNSYS. The seasonal performance of 1m² of solar thermal surface was evaluated under well-validated yearly weather conditions for the demo city of Valladolid (CARTIF-III building).

Figure 43 depicts the final output of the simulations, i.e. a graph presenting the relationship between the coefficients of the solar panel's performance curve measured on-site and its impact on total useful energy delivered to meet the heating loads. This graph, created in the design stage, will be used by the workers to support them performing the self-inspection activities.

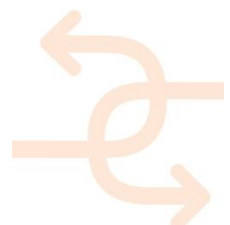

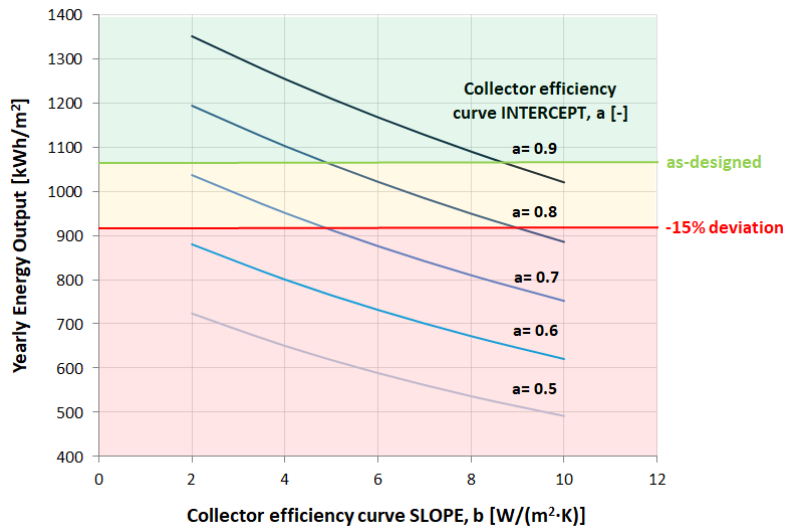

Figure 43: Decision-support graph relating the coefficients of the performance curve (intercept and slope) and the yearly thermal energy delivered by the solar collectors

Step 2.- (a) Representative testing conditions were selected: $I = 800 \text{ W/m}^2$ (sunny), Inlet temperature = 25 °C (starting from cold storage), ambient temperature = 30 °C, wind velocity = 1-4 m/s, test duration = 15min

(b) Then, two different operating conditions were measured according to the considerations describe before. Table 18 summarizes the measurement results.

Operating point	T _{in} (°C)	T _{out} (°C)	T _m -T _a (°C)	M (kg/h)	Q (W)	T* (°C·m ² /W)	Thermal eff. (%)
Point 1	25 °C	57	11	30	1114.7	0.01375	69.67
Point 2		78	21.5	15	923.1	0.02687	57.69

Table 18 : Measurement results of the example test for impact diagnosis

Step 3.- Based on the results previously obtained, the on-site approximate solar collector performance curve is obtained and compared to 'as-designed' curve provided by the manufacturer (see Figure 45). It is clearly observed that the heat loss coefficient of the curve measured on-site is higher than expected as-designed, so the collector field will probably demonstrate poorer performance in the long term. Whether it is acceptable or not will be decided when completing the self-inspection process. The measured performance curve is $\eta = 0.82 - 9.12 \cdot T^*$.

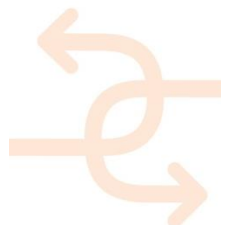

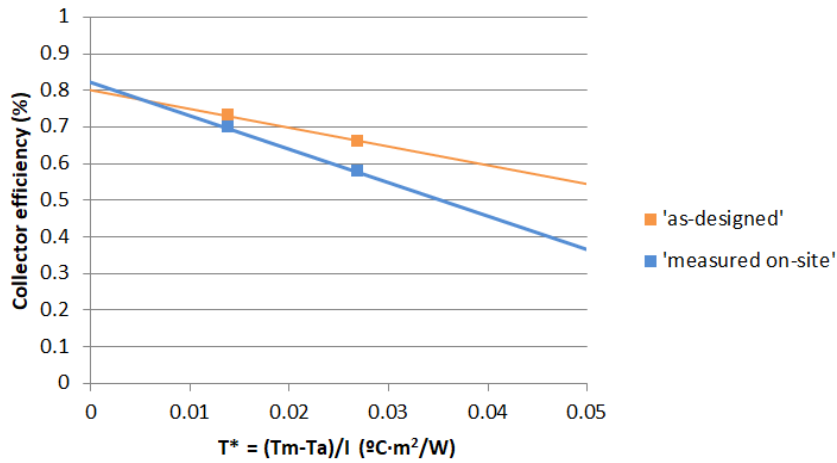

Figure 44: Comparison of 'as-designed' and 'measured on-site' collector thermal performance curves

Step 4.- Considering the coefficients of the performance curve measured on-site, it is possible to make direct use of the simulation-based decision-support chart. Figure 45 reveals the deviation already identified between the as-designed and measured curves and allows the on-site worker to estimate the long term impact of such deviation as well as to decide if the deviation is assumable or not.

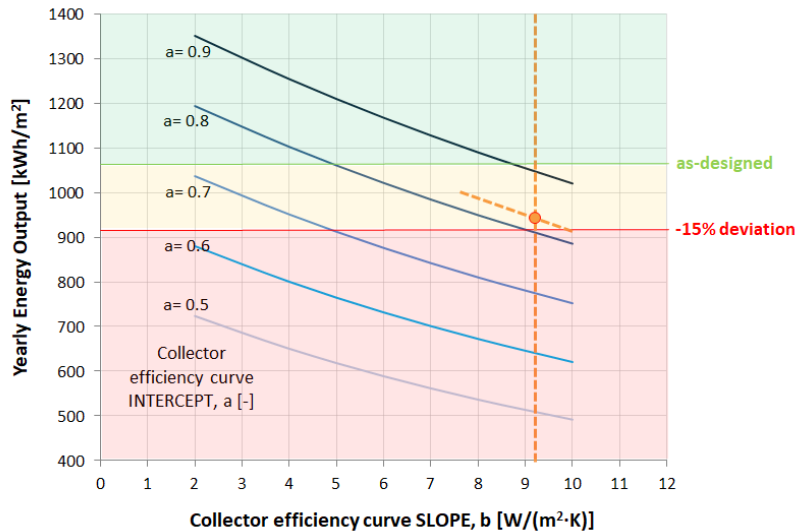
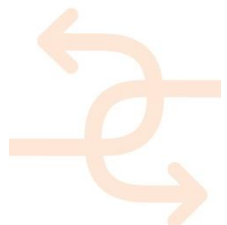

Figure 45: Practical application of the simulation-based decision-support chart

Step 5.- Finally, from Figure 45, it can be observed that the loss of performance (in terms of yearly energy output) is estimated to be lower than 15% (which is here considered as threshold). Therefore, the worker can make the final decision and complete the self-inspection process confirming the ACCEPTANCE of the facility according to the available measurements and procedure.



6.5 Thresholds and tolerances

The following reference thresholds and tolerances are defined in order to avoid unacceptable deviations on the performance of the solar hot water system, as derived from INSITER measurement results. They have been selected as reasonable values based on expert technical knowledge on HVAC and solar hot water facilities. Some remarks are included in order to allow for certain flexibility depending on the particular characteristics of the technology as well as for the limitations on proposing absolute specific thresholds for these inspection tests.

A desired value (DV) is chosen as the ideal outcome to be obtained from each measurement. In addition, a tolerance range allows for uncertainty and limitations on the inspection tests, so, if the measurement is within this tolerance range, the installation should be accepted. Otherwise, the installation should be rejected and additional measures would need to be taken to correct the detected faults.

Measurement	Unit	Desired Value (DV)	Tolerance	Remarks
Primary water supply temperature (PWST)	°C	Design	+/- 10 °C	It depends on the solar collector technology and application
Secondary water supply temperature	°C	PWST	-10 °C	Higher temperature than PWST is not possible.
Solar collector efficiency (in terms of estimated Yearly Energy output)	kWh/m ²	Simulated output based on as-designed performance	-15%	The decision-support chart should be used for comparison. (see Section 6.4 for simulation-based diagnosis procedure). Flexible tolerance might be used to allow for the limitations of the inspection test (see Section 6.3)
HX primary temp. difference	°C	Design	+/- 10%	
HX secondary temp. difference	°C	Design	+/- 10%	
HX performance	%	Design	+/- 5%	e-NTU curves should be used for comparison with expected design value. Manufacturer should provide the curve or U·A (thermal conductance) of the target HX. Narrow tolerance is considered here since HX is a key element of the solar hot water system
Primary water flow	%	100	+/- 10%	
Secondary water flow	%	100	+/- 10%	
Primary pump electric power	%	100	+ 10%	If power consumption is less than expected, no problem will be annotated
Secondary pump electric power	%	100	+ 10%	If power consumption is less than expected, no problem will be annotated

Table 19 : Thresholds and tolerances for the selected solar hot water system measurements



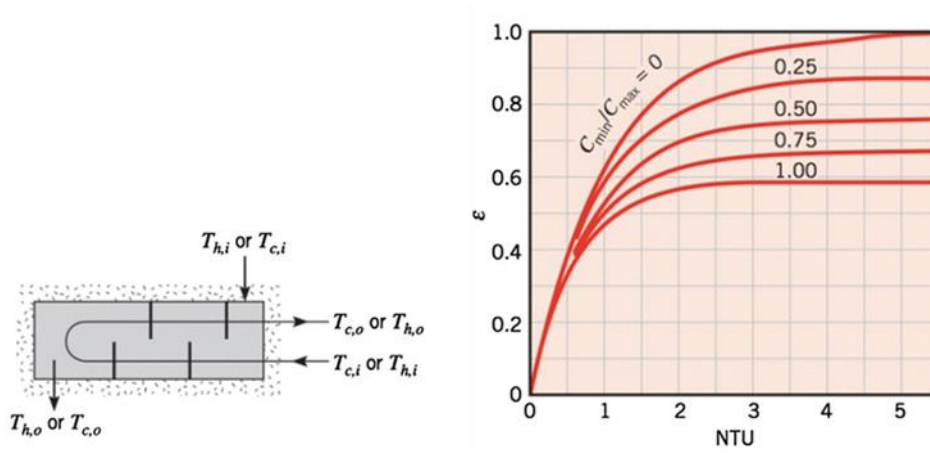
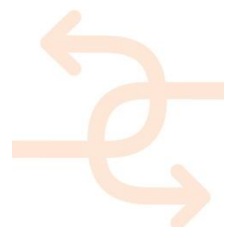

Figure 46 : Example of e-NTU characteristic curve of a given Heat Exchanger, source: [9]



7. Lighting system

Lighting systems are installed to provide buildings with artificial lighting when natural lighting is insufficient or unavailable. From a construction point-of-view, the lighting system consists of luminaires, cables and a control system. The guidelines describe inspection methods to check the consistency and correct appliance of these subsystems. The most important question here is, whether the lighting system is installed exactly according to the design. The main critical errors of lighting are in the fact that the wrong luminaires are used, or that luminaires are not located according to the lighting plan.

In modern buildings lighting control systems become more and more common. Daylight harvesting, motion and occupancy detectors and phase-pulse controls are a few well-known examples. All these systems aim to reduce energy consumption by dimming or switching off lights if artificial lights are unnecessary. Durability is an important additional benefit as longer lifetime for lighting systems can be gained.

On the other hand, dimming function (daylight harvesting) can cause functional problems. Wrong locating of the sensor or wrong setting of this function can cause undesired low illuminance levels at the working spot.

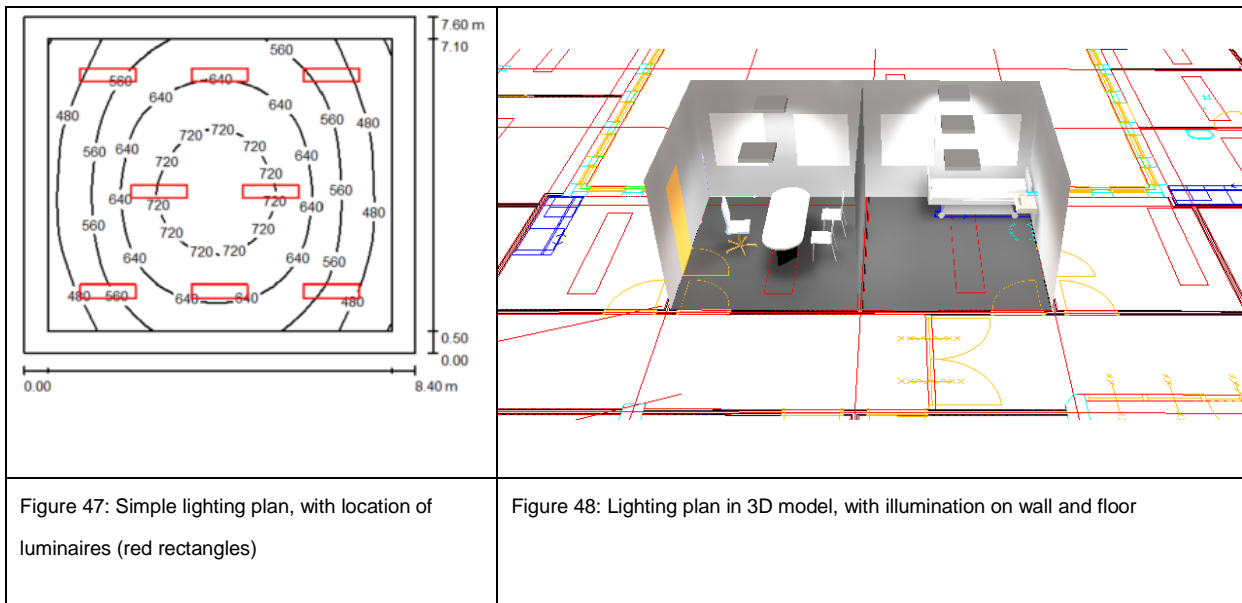

The INSITER methodology aims at reducing the most errors by means of self-inspection. Performance measurements, in this case, are of lower value comparable to the other HVAC/MEP systems. Nevertheless, the measurements that are aimed to be conducted will confirm the correct operation of the lighting systems, focussing on the interaction between lighting control and luminaires.

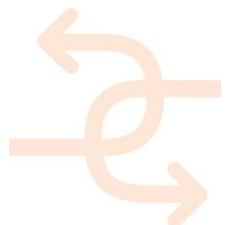

7.1 Measurement protocols and related variables

The purpose of the functional measurements is to ensure that the system achieves the design conditions and operates correctly during different environmental changes (daylight influences). In INSITER we defined a set of KPIs related to the energy efficiency (EE) and indoor environmental quality (IEQ). Each of these KPIs will be validated by measuring the relevant values in order to be able to evaluate the quality of the delivered work.

As stated before, the contribution of measurements to the improvement of lighting systems is smaller than with the other MEP systems. Therefore conducted measurements are reduced to the minimum of required output values following the procedure as described in this chapter.

For the lighting system, the table below shows the relevant KPIs and desired measurement protocol to evaluate the performance.

KPI	Measurement protocol	Description and goal
Energy use of electrical components (EE)	Energy use of lighting	The electricity use of the lighting system depends on the full load operating hours of all luminaires. The operation hours are predominantly determined by the control system, while the peak power of the lamps are determined by the luminaires. Incorrect control and wrong luminaires lead to higher energy consumption. In new buildings, there's often a maximum installed power per m2 required (W/m2).
Visual Comfort (IEQ)	Illuminance	The illuminance and its distribution on the task area and on the surrounding area have a great impact on how fast, safe and comfortable a person perceives and carries out the visual task. Wrong luminaires or wrong placement of luminaires, can cause discomfort and fatigue because of a too low illuminance on the working area. In addition, the visual comfort is negatively influenced by too great a difference with the light intensity in the direct environment. The lowest measured value with respect to the average value is a measure of the uniform distribution in the space concerned (U0).

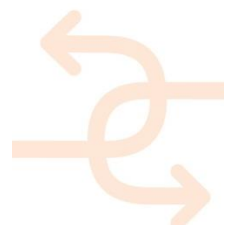

KPI	Measurement protocol	Description and goal
	Colour temperature	The color of the light influences the human good and well-being. The color is mainly determined by the color of the light source. This determines the direct component of the luminous flux. This is indicated by the manufacturers and can be measured. The colour appearance of a group of lamps in a room depends on the illuminance level, colours of the room and furniture, surrounding climate and the application. <i><u>Environmental conditions strongly influence lighting performance and measurements are very comprehensive. Therefore, measurements of colour temperature will not be conducted with the INSITER tools. Nevertheless, a check if lamps/luminaires with the right colour temperature are delivered and applied is done during self-inspection (step 2 of the guidelines).</u></i>
		Note: RA or the CRI (Colour Rendering Index) is the ability of a light source to reveal the colours of various objects faithfully in comparison with an ideal or natural light source. So the quality of the light is determined by the extent to which the entire spectrum of visible light is equal to that of the sunlight. For this purpose, 14 frequencies have been determined in the spectrum of the visible light, which are measured to determine the quality of the light. The RA value for the light that leaves the luminaires is specified by the manufacturers and will also be checked during self-inspection in step 2.
	UGR value	Glare is the sensation produced by bright areas within the visual field, such as parts of the luminaires. Glare shall be limited to avoid errors, fatigue and accidents. UGR of the luminaire is almost completely linked to the structure of the luminaire and is specified by the supplier. Discrepancies from desired UGR values are mainly caused by wrong luminaires, wrong placement of luminaires and by other factors (like windows and/or roof lights). Because measurement of UGR is very comprehensive and the result is minimal, this will not be conducted with the INSITER measurements. The self-inspection check on the right specifications of the luminaires in step 2 of the guidelines will be sufficient.

Table 20: Relevant KPIs and related measurement protocols for the lighting system



7.2 Real measurements and related devices

The purpose of this section is to provide further details about the measurement variables and protocols required for the calculation and evaluation of the selected KPIs. Important aspects such as when (time planning), by whom (executer/responsible staff) and how (details of the measurement procedure, necessary devices, etc.) will be addressed next.

It should be noted that the measurements on room level are carried out before building delivery, and therefore may not be representable for the values once the building is occupied. The design of a lighting plan is based on a specific layout of the room and furniture. While measurements are carried out, furniture is not placed yet and so any change of the layout after building delivery may affect the visual comfort in the room. Nevertheless, evaluation of the measurements on the performance of the lighting system is possible, and may resolve any or some possible errors on forehand.

7.2.1 General procedure and considerations

Before starting the functional measurements, the following actions need to be taken:

Action	Description
1 Determine the time and planning of measurements	Time and planning is crucial for INSITER’s methodology.
2 Link the measurement to an executer	For each measurement, the level of competence and qualities needed to conduct the measurements is specified.
3 Define test conditions and calculations	Functional measurements can take place at other conditions than design conditions. The measurements are allowed to be calculated into design conditions if this is possible. (e.g. possible: illuminance, not possible: UGR values)
4 Select the measurement instrument(s)	For each measurement, one or more instruments are needed. The instruments will be selected based upon their usability on site, the accuracy (or uncertainty) and practical implementation in INSITER methodology. Only calibrated devices shall be used.
5 Define the number of measuring points	For certain measurements, it might be necessary to take multiple measurements at multiple locations. For example the location and number of the measurements can be determined based on the size of the room.
6 Specify the measuring location(s)	The exact locations where the measurements are being carried out will be specified. Which building part, floor, room, etc.
7 Perform measurement	Describe the actions needed to perform the measurements.
8 Calculations and input of measured values	If applies and if possible, measurements are allowed to be calculated into design conditions or into qualifiable values. Equations are given.

Table 21: Specifications of the measurement protocols: General procedure

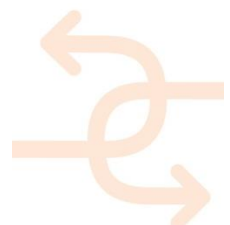

7.2.2 Measurements

Electricity use of a luminaire

1. Planning: The power of the luminaire is measured after installing the lighting system in the room. All components, like drivers and cable connectors must have been installed correctly (see inspection protocols).
2. Executor: The executor must have electrical skills and know about safety measures concerning electrical installations. Taking measurements require logical-thinking skills, math skills and basic technical skills. In some cases national certificates may apply.
3. Condition: The electrical characteristics shall be measured with the luminaire working at peak power. This means that all control systems must be set to maximum light demands (no daylight influence, if daylight harvesting is applied). The control system is set to maintain steady conditions during the measurement.
4. Instruments: The electrical power of a luminaire is measured directly by a power meter (watt-meter). For measuring, power meters of an accuracy up to $\pm 1,0$ W shall be used. Both electromechanical and electronic watt meters always measure the dissipated power.
5. Number: The number of measurements equals 5% of each type of luminaire used, with a minimum of 2 luminaires.
6. Location: Location of the measurement is outside the luminaire, but within 1 meter of the unit, to exclude cable influences.
7. Description: Note that not the electricity use is measured, but the maximum power of the luminaire. The wattmeter is an instrument that uses voltage and current to determine power in watts. A wattmeter has four connection pinches. Two for voltage and two for current. The figure below shows how a wattmeter should be connected. The measurement should be conducted over a short period of time, until a stable value is received.

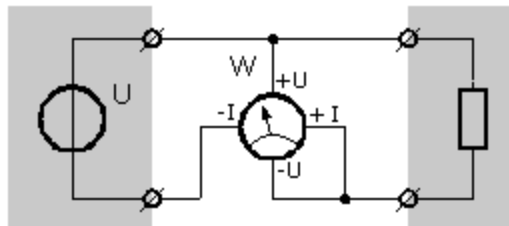

Figure 49: Connecting a wattmeter

Calculation: Note: there's no calculation needed. The following calculation is used to show the relation between power and energy use of a lamp.

The wattmeter gives the electrical power P . From the measured power, an electricity use can be calculated using the following equation:

$$E = P \cdot t$$

Where t is the full-load operation time of the luminaire. The design operating hours should be used, because the real operating hours are not yet known.

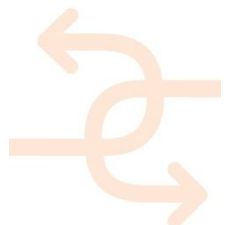

Illuminance

- 1. Planning: The measurement of illuminance at the working area will be conducted after realisation of the lighting system. All construction elements, like walls and ceilings, must have been mounted and finished off. The measurement is conducted before hand over of the building.
- 2. Executor: Taking measurements require logical-thinking skills, math skills and basic technical skills. In some cases national certificates may apply.
- 3. Condition: The room should be at normal operating condition, meaning that the indoor conditioning installation should work . Measurement will be conducted at an imaginary working spot, according to the design model. Before the measurement is carried out, the windows are blinded (with wall-colour corresponding material) to prevent disturbing natural or artificial light from outside to enter the room. When verifying illuminances, account should be taken of the design assumptions made about surface reflectance, etc., compared with the real values.
- 4. Instruments: For measuring illumination, a calibrated class A or B instrument is required.



Figure 50: Luxmeter

- 5. Number: At least one measuring position is required, in the middle of the future working area. For better result and if furniture is already placed, an illuminance grid can be used for measuring, following the procedure in EN 12464-1.
- 6. Location: The lux is measured where the working area will be located. The location according to the design illumination grid must be followed. If necessary, a stand or tripod or a temporary desk is used.

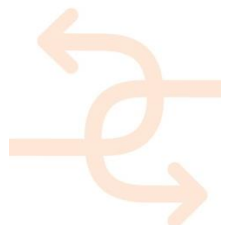

7. Description: First the meter has to be reset. A cap is placed on the probe while doing this. Then the probe is positioned on the imaginary surface (i.e. the location where the working area will be). After a short period of time, the reading is stable and measure can be taken.

A few cautions:

- Make sure the light of conventional light sources is turned on at least half an hour in advance so that the light emission of is stable. This is not necessary for LED lamps;
- Watch out for natural sunlight. The measurements should take place in the evening or night hours or in a blinded room.
- Make sure that your body or any obstruction does not block the direct radiation of the light source;
- Measure with a standard if necessary;
- Note the positioning of the probe with sensor, it should be placed horizontally on the work surface.

For measurement of the vertical light intensity, hold the probe vertically above the work surface.

- For control over the requested value the measured illuminance after installation has to be reduced with the end of life correction factor (L-value). For example, at L80, the end of service life is specified as the moment when the remaining lumen flow falls below 80% of the specified value. At 80% of the specified value, the requested lux value has yet to be met.

8. Calculation: Calculate the uniformity of the lighting on the basis of a room according to the design with a relevant grid of measurements. For instance per 4 m² and critical values from the design program.

7.2.3 Test report on the measurements

For all measurement procedures, the report of the results shall contain the following information:

- Set points and permitted tolerances;
- Operating conditions such as daylight factor, time of day and weather conditions (if they influence the measurement results);
- Measuring locations and measuring points and drawings, if used;
- Used measuring instruments and procedure;
- The measured values including date and time;
- Evaluation of the measurements (within or outside the permitted tolerances).

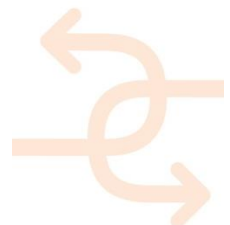

7.3 Identification of difficulties

7.3.1 Difficulties

Based on the previous sections, the inspection of a list of measurements is proposed to help the worker identify critical problems during the installation phase that might reduce systems' performance in the following stages of the building life causing delays, more intensive maintenance and/or increasing operating costs. Because the measurements need to be practical and simple, a few aspects, related to measurements of lighting systems, need attention:

- **Time:** Other than with the heat pump and ventilation system, time is of less concern with lighting. From the moment the lighting system is operational, measurements can be carried out. With lux measurements though, it's important that the last phase of construction is finished.
- **Conditions:** Power measurement is easily done. But measuring the illuminance is very sensitive. Light from inside and outside the building gives distortion and cannot be count on. Meaning that the measurements do not give good result if daylight is entering the room.
- **Accessibility:** This can be an issue with measuring the power of the luminaires. They are placed in the ceiling and if the space above the ceiling is not accessible, the measurement will be hard to carry out, if possible at all. Accurate planning is the key.
- **Uncertainties:** Every measurement is always subject to an uncertainty which arises from the layout and method of measurement, the measuring equipment, and from taking the reading. The information on the uncertainty of the equipment is supplied by the instrument manufacturer and should not exceed the coverage probability of approximately 95 %. The uncertainty of method and taking the reading should be reduces to a minimum by using skilled people to carry out the measurements and provide them with adequate instructions.

7.3.2 Limitations

Next to the difficulties, there are also some limitations to the inspection process of the lighting system:

- The electricity use of the entire lighting system cannot be measured. The most accurate way is to follow INSITER's procedures by measuring the power of all light groups in the distributor panels and calculate into predicted energy use, based on the operating hours of the design.
- The selected measurements, like stated before, do not fully cover all the necessary lighting tests, but focus on the critical performance and quality indicators, as defined in D1.6. Also, not all KPIs from D1.6 are addressed by measurement (UGR and colour temperature), due to impossibilities of a practical approach during construction.
- Measurements will be carried out by skilled workers. This is not any different from the current practice, but nevertheless important to recognise that they are subject to regional legislation and possible practical restrictions.

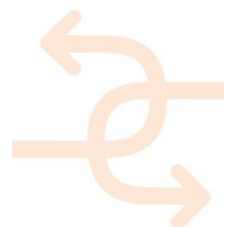

7.4 Diagnosis and related KPIs

The purpose of this section is to define a procedure to diagnose the impact of measured deviations on the real performance of the lighting system. Because of the mentioned limitations of the inspection stage, measurements taken on instant or relatively short tests are not directly representative for the real performance of the entire system.

Besides, for lighting systems a few KPIs are not (representatively) measurable during construction and should be diagnosed without measured values. The table below shows plain and simple the desired protocols and related KPIs.

KPI	Measurement protocol
Efficiency of electrical components (EE)	Electrical power of the luminaire
Visual Comfort (IEQ)	Illuminance
	Colour temperature
	UGR value

Table 22 : KPIs and related measurement protocols

7.4.1 Efficiency of electrical components

The performance indicator that influences the efficiency and eventual electricity use of electrical components is the nominal power of luminaires. The electricity use of the lighting system is not calculated. Instead, the simulation based self-inspection, as introduced in section 3.2, will be applied. For the lighting system, it means that the electrical (nominal) power of the luminaire must be simulated by the design team, to determine their impact on the overall energy consumption of the building.

During this execution, the simulation software (Vabi Elements) is used to determine the impact and create a graph wherein the relation between the deviated KPI value is set against the overall energy consumption.

Electrical power of the luminaire

The nominal power of a luminaire determines for an important part the overall electrical energy use of the lighting system. With given operating hours, that can also be influenced by presence detectors; a deviation to the design value will influence the energy use for the entire lighting system and thus, the overall energy use of the building.

In the next example, the installed nominal power of the lighting system (expressed in W/m²) is simulated. On the x-axis the deviation to the design value is given, both positive as negative values. In this particular case, the nominal power of the luminaires at 0% corresponds to 10 W/m² and according to design specification. On the vertical (y-) axis the simulated impact on the energy consumption is given. In this lighting case, a 10% higher power use of the luminaires, leads to an energy consumption of 668779 kwh/year (3,0% higher energy consumption of the total building).

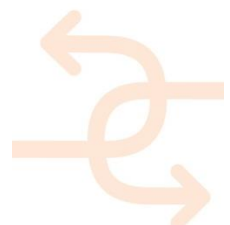

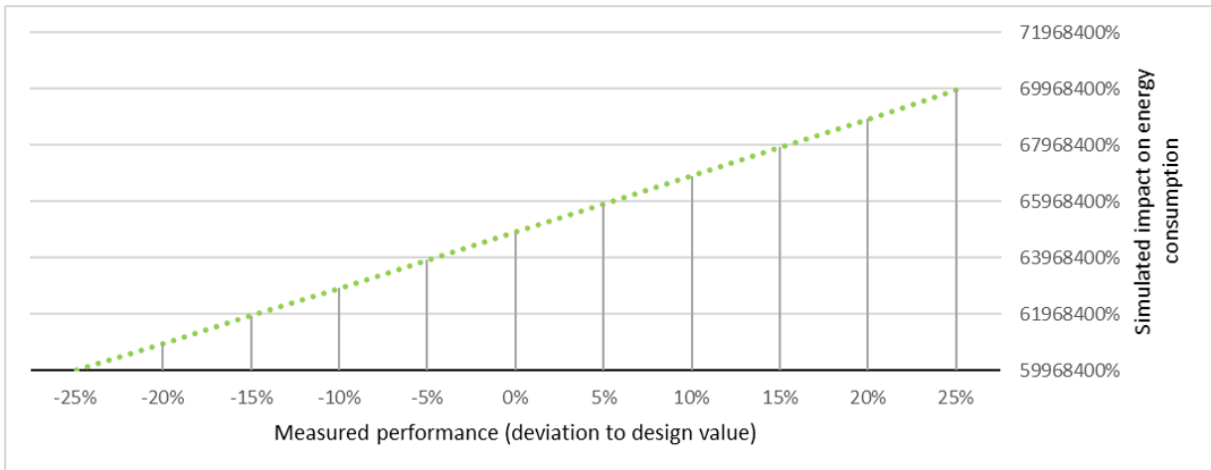

Figure 51: Relationship between measured performance and simulated impact on energy consumption

After simulating the relationship between measured nominal power of the luminaires and the impact on actual energy consumption of the building, the building designers together with commissioning experts have to agree and indicate the boundaries that determine the KPI threshold. For example, if agreed that the nominal power may not lead to an overall energy consumption deviation of 1% (boundary) (about 655428 kwh/year), the threshold will be approximately +3,0% (see Figure 52).

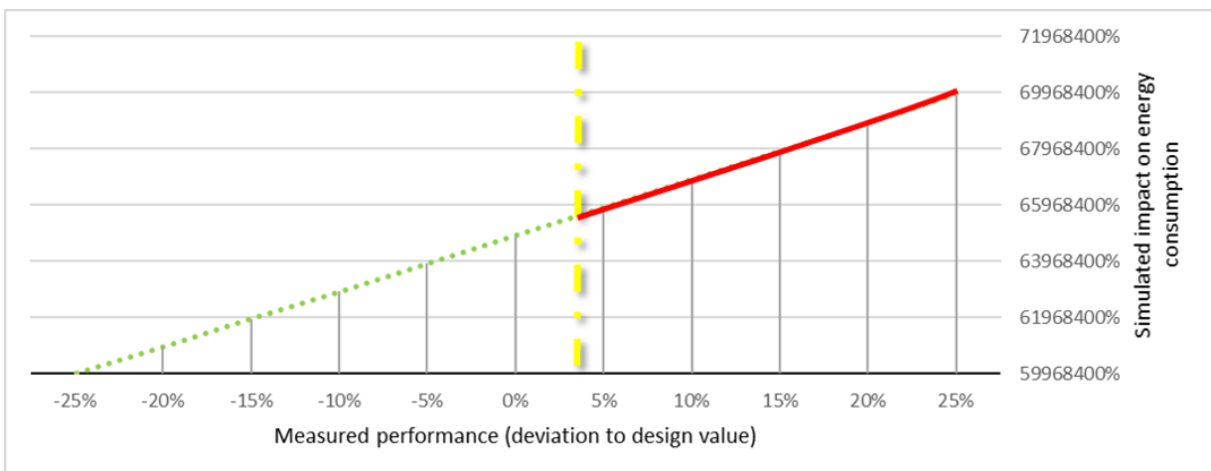

Figure 52: Threshold based on a simulation approach

During the construction phase, the power measurements will be taken during the self-inspection process. The outcome of these measurements are then compared to the threshold from the simulated graph. In this particular case, a nominal power of 3,0% more than the design values, means rejection. This equals an nominal power of the luminaires of 10,3 W/m².



7.4.2 Visual Thermal Comfort

The visual comfort is mainly defined by the:

- Illuminance,
- Colour temperature, and
- UGR value.

The diagnosis of a correct colour temperature, RA/CRI and URG is done by self-inspection. The MEP worker checks if the delivered luminaires correspond with the desired specifications. This is part of the guidelines (D1.2 and D1.3). For illuminance, the measurement is influenced by other light sources. By executing the measurements under conditions where these external factors are eliminated, the measured values represent a correct (average) illuminance and can directly be diagnosed as satisfactory or unsatisfactory. Stressed the fact that the requested value of the measured illuminance after installation has to be reduced with the end of life correction factor (L-ware).

7.5 Thresholds and tolerances

The following reference thresholds and tolerances are defined in order to avoid unacceptable deviations on the performance of the lighting system, as derived from INSITER measurement results.

A desired value (DV) is chosen as the ideal outcome to be obtained from each measured KPI (MV, the measurement value), generally the design value. In addition, a tolerance range allows for uncertainty and limitations on the inspection tests, so, if the measurement result is within this tolerance range, the installation should be accepted. Otherwise, the installation should be rejected and additional measures would need to be taken to correct the detected faults.

KPI	Unit	Desired Value (DV)	Tolerance	Remarks
Electrical power of the luminaire	W/m2	Design	± 1 % on overall building EE	The simulated decision support chart is used to determine the acceptable tolerance of the nominal power of the luminaires.
Illuminance	Lux	Design	none	The MV should not exceed the minimum DV. MV is the average value of multiple measurements (see section 7.2).

Table 23: Thresholds and tolerances for the lighting system

If legal requirements or local building regulations demand closer tolerances, this shall be specially defined in the inspection report and adopted in the INSITER decision tools.

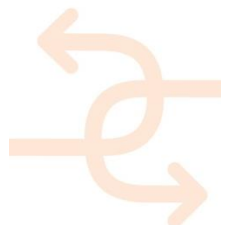

8. Discussion and conclusions

The work in D1.7 contributes to the INSITER goals by:

- Providing new measuring and diagnosis solutions for self-inspection processes performed by HVAC/MEP workers. Especially the way impact of performance deviations is quantified is very useful to support workers taking the right decision in case of deviations under special conditions (not actual conditions of the building);
- Providing new simulation-based diagnosis approach to diagnose the impact of performance deviation on related KPI's and total building quality. This approach is unique as it supports workers without the need to use heavy simulation techniques which requires heavy computing capacity and plenty of time to run simulations.

8.1 Application of the new diagnosis approach

In this document, the new approach has been limited to some measurements and performed by VABI Elements and TRNSYS as simulation software for building/HVAC/MEP. However, every measurement that has input for the simulation software can be simulated in this way and a diagnosis graph can be produced. The approach is general making it very easy to implement any commercial simulation software (no country limitations). Creating diagnosis graphs and deciding on related thresholds can be done in the design stage by the building/HVAC/MEP designers themselves. Workers don't need to have specialized knowledge to use the graphs.

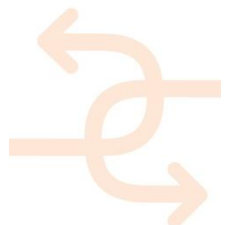

8.2 Limitations of the new approach

Along the whole building life cycle, different measurements can be proposed with different purposes depending on the specific stage of the process that is targeted: components and material reception, construction, commissioning, in-use phase, etc. The value and requirements of such measurements are completely different depending on the purpose. INSITER focuses on that stage right after the installation of building components (and MEP/HVAC systems in this particular case of D1.7) and before the building delivery, addressing the quality assurance of the installation of solar thermal systems.

The key challenge of the inspection measurements lies in the time when the tests should be conducted. This process is done at the commissioning step, aiming not only to check that systems is ready for operation, but to check that their performance can be estimated within acceptable margins in comparison to expected design values.

However, performance estimation may face several difficulties related to controllability of the testing process as well as to the available time period. In this sense, differences between in-house, in-use and INSITER measurements and possibilities become evident, thus revealing the gaps in performance that cannot be measured / inspected within the project scope:

- **FATs:** They refer to performance tests done by the manufacturer at the factory before the product or equipment delivery. They are based on well-established standard testing procedures that enable comparison of similar systems and provide guarantee of the reported performance. Proper facilities are used in order to control the testing conditions. No relevant time restriction applies.
- **In-use tests:** These correspond to the real-time measurements of the equipment performance during full normal operation conditions. Then, they are related to maintenance of the solar system. Boundary conditions cannot be controlled in this case, but real seasonal information about the system's behaviour is obtained (which directly represents the real impact of target systems on the building performance and use of resources).
- **INSITER tests:** According to the scope of the INSITER tests previously mentioned, important limitations should be considered. On one hand, there are time restrictions during the commissioning phase, so INSITER inspection measurements cannot count on long periods to wait for ideal testing conditions. At the same time, the target systems are available as installed on-site, without specific testing workbenches or dedicated facilities to control testing conditions. In fact, testing conditions cannot be controlled and must be adapted to the existing site/ambient variables (i.e. weather, spatial location, etc.). On the other hand, as long testing periods are not possible, performance values representative of weighed seasonal operation is neither possible. Then, extrapolation of measurement results should be devised to estimate real impact of performance deviations.

8.3 Total building quality and energy efficiency

According to all these arguments, the present document proposes reasoned simplified practical measurement protocols and diagnosis procedure that can be adapted to the limitations of the inspection schedule, resources and boundary conditions within the INSITER scope, and, at the same time, can provide valuable information for fault detection, quality assurance and impact estimation on the performance of the different MEP/HVAC systems.

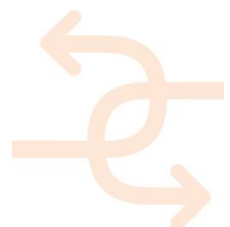

References

- [1] Broers, A. (2016) "Calculation and analytical methods for MEP/HVAC components" [report] INSITER D1.6
- [2] CEN (2006) EN 12976-1: Thermal solar systems and components - Factory made systems - Part 1: General Requirements. European standard
- [3] CEN EN 12237 (2003): Ventilation for buildings – Ductwork – Strength and leakage of circular sheet metal ducts. European standard.
- [4] CEN EN 12599 (2012): Ventilation for buildings – Test procedures and measurement methods to hand over air conditioning and ventilation systems. European standard
- [5] Coventry University, Coventry UK [website] <https://www.coventry.ac.uk/>
- [6] Dutch Building Commissioning Association (DBCxA): Testprotocol PCD 105 - Ruimtetemperatuur en relatief vocht (Room temperature and relative humidity)
- [7] https://www.sepe.es/contenidos/personas/formacion/certificados_de_profesionalidad/familias_profesionales.html
- [8] ISO (2017) EN ISO 9806 : Solar energy-Solar thermal collectors-Test methods. International standard
- [9] ISSO KennisKaarten (Knowlegde Maps): <https://kennisbank.issso.nl/bibliotheek>
- [10] Kamstrup product catalogue. [website] <http://products.kamstrup.com/index.php> Last accessed: 2018.07.30
- [11] Mehendale S.S. (2017) Single-Phase Heat Exchangers. In: Kulacki F. (eds) Handbook of Thermal Science and Engineering. Springer, Cham. https://doi.org/10.1007/978-3-319-32003-8_21-1
- [12] Park, Y. C. (2013). A study on automatic optimal operation of a pump for solar domestic hot water system. Solar Energy, 98, 448-457.
- [13] REAL DECRETO 1128/2003, de 5 de septiembre, por el que se regula el Catálogo Nacional de Cualificaciones Profesionales. Last accessed: 2018.07.24 <http://www.boe.es/boe/dias/2003/09/17/pdfs/A34293-34296.pdf>
- [14] Schulz & Berger [website] <https://www.schulz-berger.com/>
- [15] Sebastian, R. (2017) "Revised Overview of Key Performance Indicators (KPIs)" INSITER project. Important clarifications for technical research ahead
- [16] Sebastian, R. (2017) "Revised Overview of Key Performance Indicators (KPIs)" INSITER project. Important clarifications for technical research ahead
- [17] Servicio Público de Empleo Estatal (SEPE) Ministerio de Trabajo, Migraciones y Seguridad Social. Gobierno de España. Familias Profesionales [website] Last accessed: 2018.07.24
- [18] The Solar Keymark. CEN Keymark Scheme (2018) [website] <http://www.estif.org/solarkeymarknew/> Last accessed: 2018.07.31

